

# FIBREroll CS

## TEXTILE FIRE CURTAIN FOR APPLICATION TO PLACES WITH INTERRUPTED CONVEYOR SYSTEM

FIRE RESISTANCE UP TO: **E180; EW120; EI180 H20 with sprinkling system; EI60 without sprinkling system**



### PRODUCT DESCRIPTION

- › Application of a textile fire curtain type FIBREroll / FIBREroll EW / FIBREroll EI to places where the conveyor system passes through a fire dividing structure.
- › **FIBREroll CS** is usually used in industrial buildings, in which the emphasis is mainly on fire protection of penetrating openings. For example: packaging lines, material preparation, paint shops (silicon free).
- › By applying a fire curtain, we meet the requirements of our customers primarily for the flexibility of using the buildings' opening.
- › For the **FIBREroll CS** application, it is necessary to ensure the interruption of the conveyor system which allows the closure of the fire curtain to the floor or to the parapet.

### TECHNICAL PARAMETERS

- › Fire resistance **FIBREroll CS**: E30 / **EW30**; E60 / **EW45**; E120 / **EW60**; E120 / **EW90**; E180 / **EW120**; **EI30**; **EI45**; **EI60** (for higher EI fire resistance, it can be reached by using type H20 (with sprinkling system) – upon consultation).
- › Maximum dimensions recommended by the manufacturer:
  - › Fire resistance E/EW: 15 × 7 m (larger dimensions upon consultation);
  - › Fire resistance EI without sprinkling system: clear width 4,8 m × clear height 4,4 m (larger dimensions upon consultation).

- › Necessary space for **FIBREroll CS** in overhead depends on fire resistance and size of the construction opening.
  - › Standard overhead dimensions range: height 200–500 mm and depth 200–435 mm.
- › **FIBREroll CS** is designed for face fixed assembly (fixed between assembly requires additional steel frame, our projection team will assist you with the proposal).
- › For the installation of **FIBREroll CS** it is necessary to consider the space between adjacent conveyors, in case of E / EW resistance: 70 mm; for EI resistance: 90 mm (in case of draught in the fire dividing structure, it is necessary to consult with our projection team).
- › All parts of AVAPS FIBREroll CS can be considered in all RAL coating according to the customer's request.

### CONTROL

- › Control panel AOP (AVAPS Operation Panel) ensures the electronic control of individual curtain functions, including emergency closure button.
  - › System is designed in accordance with EN 14637.
- › In case of a requested closure of the fire section with the FIBREroll CS, the conveyor system is getting empty in cooperation with the control unit of the conveyor system.
- › AOP transmits the required signals to the conveyor system control unit, such as upper position, lower position, fire, fault, and other information.

### CERTIFICATION

**FIBREroll CS** is covered by CE certificate.\*

For more information, contact: [projekce@avaps.cz](mailto:projekce@avaps.cz)

Manufacturer issues declaration of performance for individual order in compliance with Regulation of the European Parliament and Council (EU) No. 305/2011.



\* The option EI with sprinkling system (type H20) is not covered by CE marking.



## TECHNICAL INFORMATION

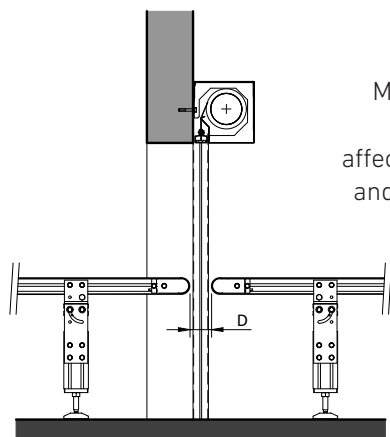

Minimum dimension  
 $D = 70$  to  $90$  mm;  
 affected by fire resistance  
 and external conditions.

In case of a requested closure  
 of the fire section with the FIBREroll CS,  
 the conveyor system is getting empty  
 in cooperation with the control unit  
 of the conveyor system.

The solution does not include  
 the control of the conveyor system;  
 in case of interest it is necessary  
 to discuss it individually.

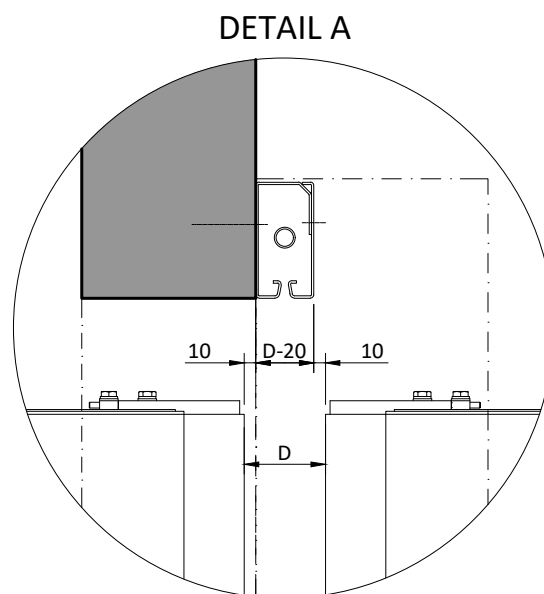
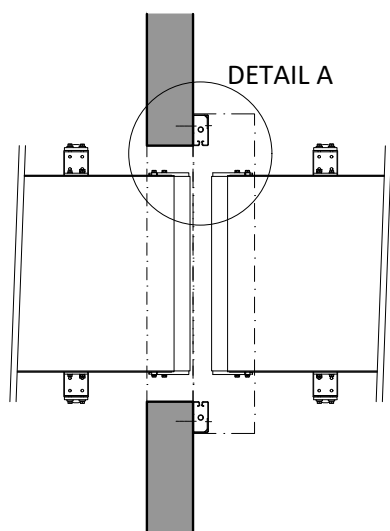

This drawing and copyright belong to AVAPS s.r.o. Do not copy without AVAPS s.r.o. authorisation.

## MAINTENANCE AND REPAIR SERVICES

We provide professional warranty and post-warranty service and revisions according to applicable laws for all our products.

Contact: +420 777 911 770 / [service@avaps.eu](mailto:service@avaps.eu)

