

## Product datasheet

Inflatable dock shelter

Type: PWI

### Contact:



Ronnenberger Straße 20  
D-30989 Gehrden

phone +49 (0) 5108 879 270  
fax +49 (0) 5108 879 2710

info@promstahl.de  
www.promstahl.de

# Inflatable dock shelter (PWI)

PROMStahl's series of inflatable dock shelters combines optimum sealing with the greatest possible variety of applications. The inflatable side and top cushions provide airtight contact with the vehicle. This type of shelter is thus ideal for temperature-controlled warehouses to seal against summer heat, winter cold, draught, dust and insects. The results are substantial savings on energy, improved working environment, production and safety. Moreover, the shelter reduces the possibility of unauthorized personnel entering the warehouse through the loading bay doorway, hence considerably reducing loss through theft. The inflatable top and side cushions not only guarantee optimum sealing but also automatically adapt to the truck measurements. This feature means that trucks of varying sizes can be sealed effectively. Offering a very good payback period PROMStahl dock shelters are a highly cost-effective investment.

## Aesthetic and practical advantages

The top-quality materials used by PROMStahl are extremely durable. The inflatable dock shelters are made of high-grade 'Cordura', a material that has many favourable qualities, including excellent tear resistance, good colour fastness and strong resistance to damp and mould formation.

The front and the rear frame of PROMStahl dock shelters consist of extruded aluminium sections. The lateral frame is particularly robust and consists of insulated panels (thickness: 40 mm). Since PROMStahl's inflatable dock shelters are already pre-mounted (they are delivered in just three parts), installation of this type of dock shelter is very fast and easy. Considerable cost and time savings are the advantages of this design. Moreover, this dock shelter combines the best possible sealing effects with aesthetics and function.

## Additional plus points

PROMStahl's inflatable dock shelters are available in two different versions. With the first version the PWI is mounted to the loading bay; in this case the warehouse floor and the vehicle lorry bed have approximately the same height (available with an outer height of 3600 mm and 4000 mm). An installation height of 4700 is recommended.

Since there are also loading situations without a ramp, we developed a second version of our dock shelter PWI (outer height 4700 mm).

When not in use (i.e. not inflated), the cushions are hidden behind the front curtains (consisting of 3-mm PVC) so that the lorry driver has a perfect view of the loading area during the docking process. As soon as the vehicle is in the shelter, the cushions are inflated within 11 seconds making a tight seal with the sides and top of the vehicle body. After the loading/unloading process the cushions are deflated in just 25 seconds.

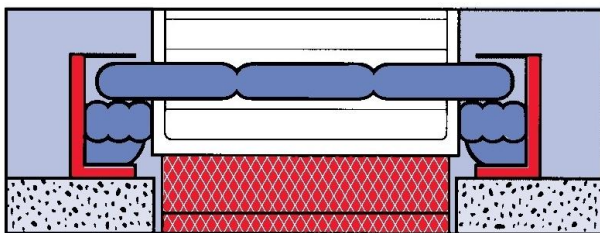

Furthermore, the cushions cannot get into the lorry opening like it is common with the curtain-type dock shelters. Consequently, an optimal accessibility of the lorry bed as well as a maximum operating range on the ramp can be guaranteed. For dock shelters up to an outer height of 4700 mm integrated inflatable rear bottom cushions are standard resulting in optimum sealing of the whole system. Power supply system: Protection IP 65, 230/400 V - 50 Hz.

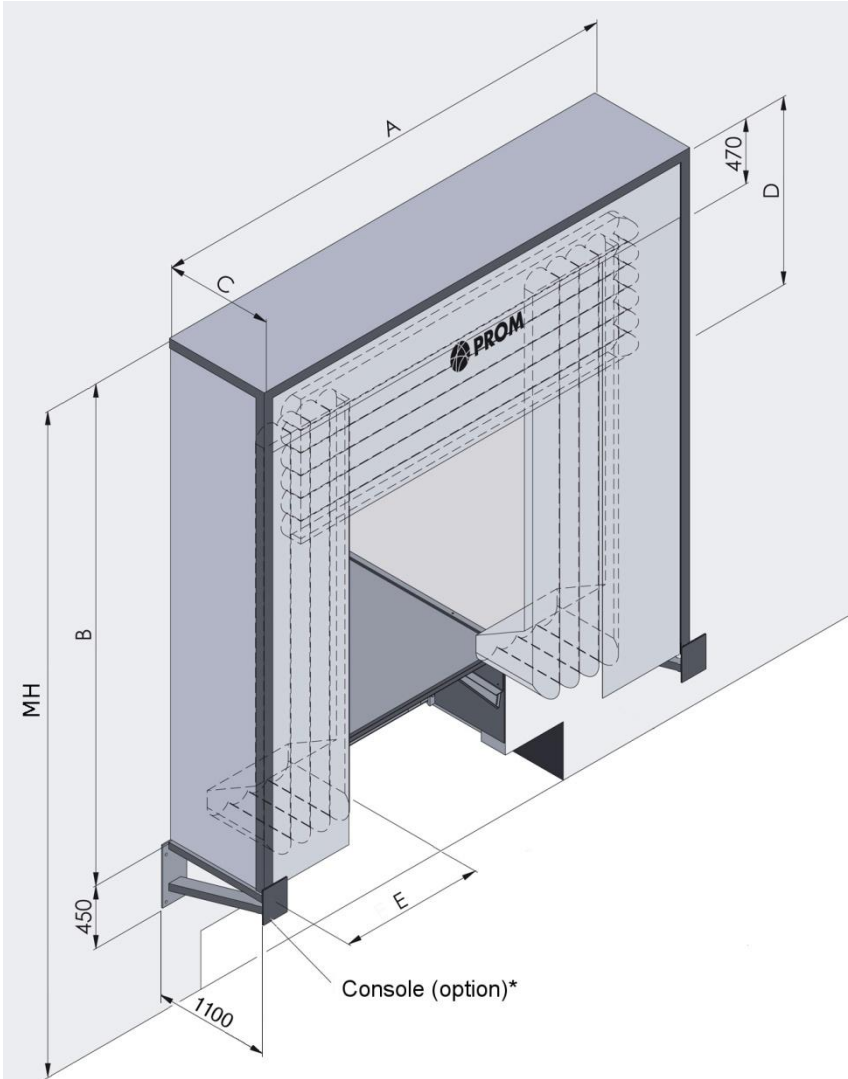

- A Outside width
- B Outside height
- C Depth (projection from building façade)
- D Height of top seal (inflated)
- E Width of side seal (inflated)
- MH Installation height (recommendation 4700 mm)

\*Console (option) only for outside height (3600 and 4000 mm)

A	B	C	D	E
3500, 3600, 3700	3600, 4000, 4700	920	1350, 1750	650
All dimensions in mm.				

Total width (A)	Total height (B)	Width of opening (inflated)	Height of opening (inflated)	
			D = 1350	D = 1750
3500	3600	2200	2250	1850
3600	3600	2300	2250	1850
3700	3600	2400	2250	1850
3500	4000	2200	2650	2250
3600	4000	2300	2650	2250
3700	4000	2400	2650	2250
3500	4700	2200	3350	2950
3600	4700	2300	3350	2950
3700	4700	2400	3350	2950

All dimensions in mm.

## Curtain specification

Top curtain and side curtain characteristics:

- double-layer PVC-coated polyester cloth
- total weight: about 3800 g/m<sup>2</sup> in accordance with the EN ISO 2286-2 standard
- material thickness: 3 mm
- temperature stability: -25° C/ +70° C
- low flammability in accordance with the DIN 75200 standard
- tensile strength / maximum tensile force in accordance with DIN EN ISO 1421/V1
  - longitudinal tensile strength: about 7000 N/ 50 mm
  - transverse tensile strength: about 4300 N/ 50 mm
- tear propagation strength in accordance with DIN 53363
  - longitudinal tear propagation strength: about 1000 N
  - transverse tear propagation strength: about 900 N

Side and top cushion:

- Polymar material, tear-proof material with inside cloth
- total weight: about 600 g/m<sup>2</sup> in accordance with EN ISO 2286-2
- material thickness: 0,5 mm
- temperature stability: -40° C/ +70° C
- low flammability in accordance with DIN 75200
- tensile strength / maximum tensile force in accordance with DIN EN ISO 1421/V1
  - longitudinal tensile strength: about 2000 N/ 50 mm
  - transverse tensile strength: about 2000 N/ 50 mm
- tear propagation strength in accordance with DIN 53363
  - longitudinal tear propagation strength: about 200 N
  - transverse tear propagation strength: about 150 N

