

Product datasheet

Hydraulic dock leveller with telescopic lip

Type: PT

Load capacity: 60 kN

Contact:



Ronnenberger Straße 20
D-30989 Gehrden

phone +49 (0) 5108 879 270
fax +49 (0) 5108 879 2710

info@promstahl.de
www.promstahl.de

Contents

- General information3
 - Overview.....3
 - Standard parameters4
 - Options4
 - Design characteristics.....5
- Telescopic lip5
 - Standard telescopic lip.....5
 - Telescopic lip options.....5
- Platform.....6
 - Tear-plate thickness.....6
 - Toe guards6
 - EPDM sealing7
 - Anti-slip / anti-noise coating7
 - Front curtain8
 - Platform insulation8
 - ISO-KIT.....8
- Surface treatment.....8
 - Painting.....8
- Hydraulic unit9
- Frames / pits9
 - T frame (to be embedded in concrete)9
 - W frame (in combination with a pre-frame)10
 - F frame (flat steel frame for leveller replacement)11
 - P frame (mounted in the pit).....12
 - B (box).....12
 - Stepped version13
 - Control units13
- Accessories.....15
 - Buffers15
 - Fixed-position buffers.....15
 - Height-adjustable buffers16
 - Floating buffers17
 - Buffers with protective housing17
 - Wheel chock19
 - Traffic lights19
 - Dock light.....19
 - Wheel guides19
- Electrical preparations (by others)20

General information

The PT stationary dock leveller with telescopic lip is a new product of PROMStahl's wide product range. This top-quality product benefits from over 25 years of experience in the field of design and manufacture of docking technology. The hydraulic version of the PT leveller is operated at the touch of a button and after exact positioning of the telescopic lip automatically follows the movements of the vehicle during the loading or unloading process (automatic floating position). The big advantage of this type of dock leveller is the maximum flexibility of the lip length. Thanks to this feature effective loading and unloading even of vehicles that are not completely correctly positioned can be guaranteed and time-consuming and complicated repositioning of the vehicle is not necessary. The PT dock leveller is supplied including frame and installed in the pit as a compact unit in just one step. Additional supports are not necessary. Considerable savings in installation and its tail-lift recess, i.e. the possibility to accommodate tail lifts, are the big advantages of this type of installation. Alternative frame types are available depending on the individual building situation. The load capacity corresponds to the axle load limit taking into consideration the most unfavourable loading case. The PROMStahl dock levellers meet all requirements of the European standard Norm EN 1398 and has passed the GS safety tests.

Overview

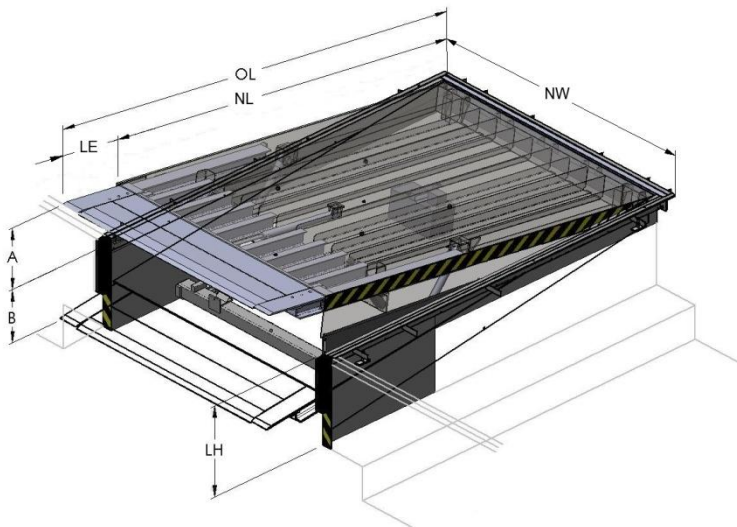

- NL Nominal length
- NW Nominal width
- OL Overall length [NL + LE]
- LE Lip extension
- LH Leveller height
- A Level equalisation above dock
- B Level equalisation below dock

In accordance with the EN 1398 standard, the leveller must not be used beyond the permissible gradient range of $\pm 12.5\%$ (ca. $\pm 7^\circ$). The limits may only be exceeded if the operator ensures that the danger of slipping has been eliminated (e.g. due to dry and clean surfaces).

Dock leveller		LE=500		LE=1000	
NL	LH	A	B	A	B
1750	700	250	350	-	-
2000	600	300	290	360	360
2000	700	315	405	390	480
2500	600	450	270	510	310
2500	700	470	400	555	460
3000	600	430	250	500	280
3000	700	450	400	520	450
3500	800	520	400	590	450
4000	800	500	410	560	450
4500	800	500	410	555	450
Nominal width (NW) 1750, 2000, 2100, 2200, 2250, 2400 for all sizes					All dimensions in mm.

Load capacity for all sizes 60 kN (dynamic), 84 kN (static)
Other load capacities and sizes on request.

Standard parameters

Lip (steel)	Lip length: 500 mm Chamfered section: 40 mm Tear-plate thickness: 13 mm/15 mm
Platform	Tear-plate thickness: 8 mm/10 mm
Frame	T frame (leveller frame to be embedded in concrete) W frame (in combination with a pre-frame) Pit frame (only for pits without tail-lift) NL ≤ 3000 mm
Surface	Painted, standard colours: RAL 5010, RAL 7016
Hydraulic unit	Hydraulic unit: (1.5 kW) - 2 lift cylinders with emergency stop valve - 1 lift cylinder for the telescopic lip
Control unit	Control unit with auto button

Options

Lip (steel)	Lip length: 1000 mm (as of a nominal length of 2000 mm) Chamfered section: 100 mm Telescopic lip with tapered edges (125 mm on both sides) Telescopic lip with lateral retracting tongues (150 mm on each side, only for telescopic lip of 500 mm) with tear plate thickness 13mm/ 15 mm
Frame	F frame (flat-steel frame for leveller replacement) B frame (box) Stepped version
Surface	Painting in different RAL colours and various layer thicknesses Hot-dip galvanisation
Hydraulic oil	Organic oil Low-temperature oil (- 30°C to + 60°C)
Control unit	Special control unit with additional options PROMControl
Others	EPDM sealing Anti-slip coating Platform insulation: ISO panel (thickness: 40 mm, 60 mm) ISO KIT (40 mm/ 60 mm/ 80 mm panels) Front curtain

Design characteristics

The PT telescopic lip leveller is provided with the CE and the GS (safety-tested) labels and meets all requirements of the EN 1398 standard. The standard load capacity of 60 kN (dynamic axle load) corresponds to the EN 1398 standard for a forklift wheel contact surface of 100x150 mm. Higher concentrated loads as well as higher load capacities are available on request at short notice

Telescopic lip

Standard telescopic lip

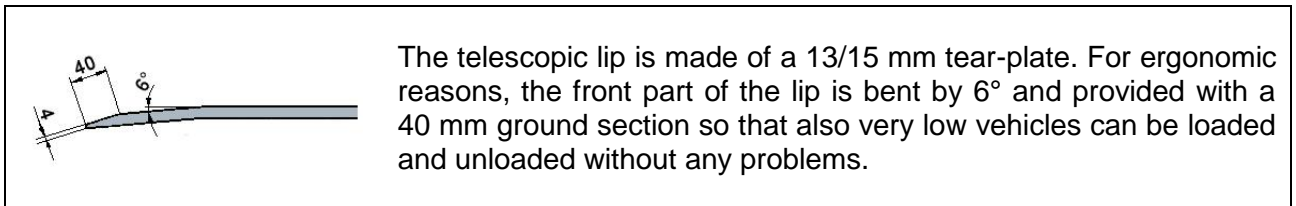

Telescopic lip options

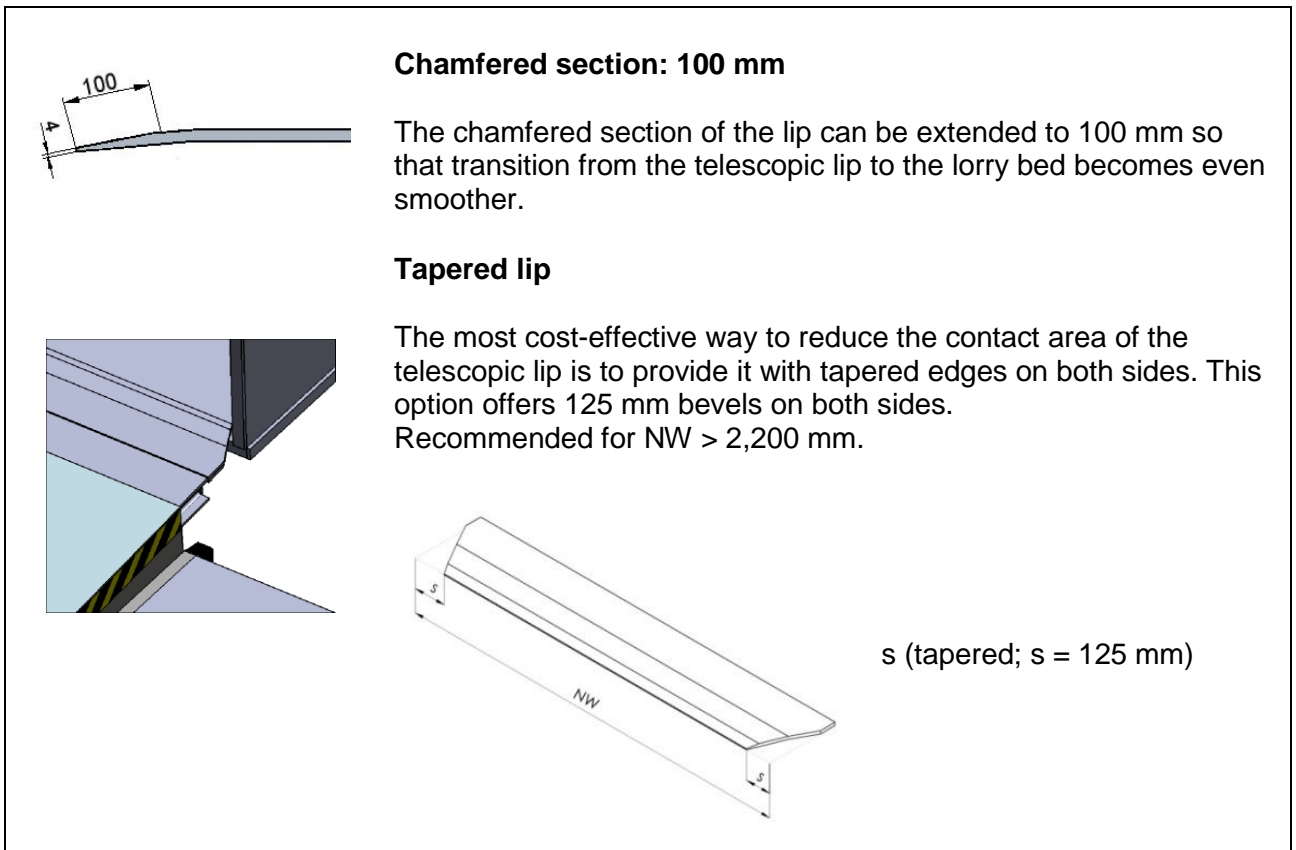

Telescopic lip with lateral retracting tongues

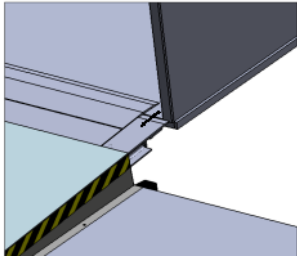

The PT dock leveller is also available with retracting tongues. In this case the lip consists of a central element and two side elements (located on left and right hand side). The side elements move backwards independently of the central element. Thus, the lip width is automatically reduced so that vehicles with narrow beds can also be loaded and unloaded. When the lip is fully retracted, the side elements are automatically locked in their original position so that the central and side elements are extended together again during the subsequent loading process.

Recommended for NW >2,200 mm.

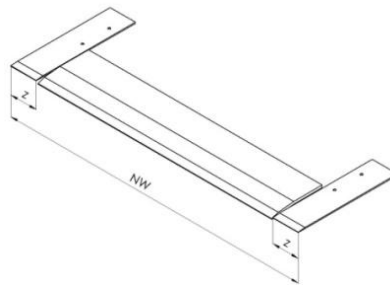

retracting tongues
z = 150mm
(only for LE= 500)

Platform

Tear-plate thickness

The platform is made of high-quality tear plate material (S235JRG2) and supplied with a thickness of 8/10 mm. It is strengthened by means of special reinforcements guaranteeing optimal stability as well as a sufficient transverse torsion strength of up to 10% of the platform's width.

Toe guards

The PT dock leveller is always provided with lateral toe guards to prevent foot injuries when the leveller moves downwards.

EPDM sealing

The EPDM sealing is used to seal the gap between the dock leveller and the pit so that draught in the warehouse building is reduced, the staff's working conditions are improved and energy can be saved. The EPDM sealing is installed on the three sides of the leveller.

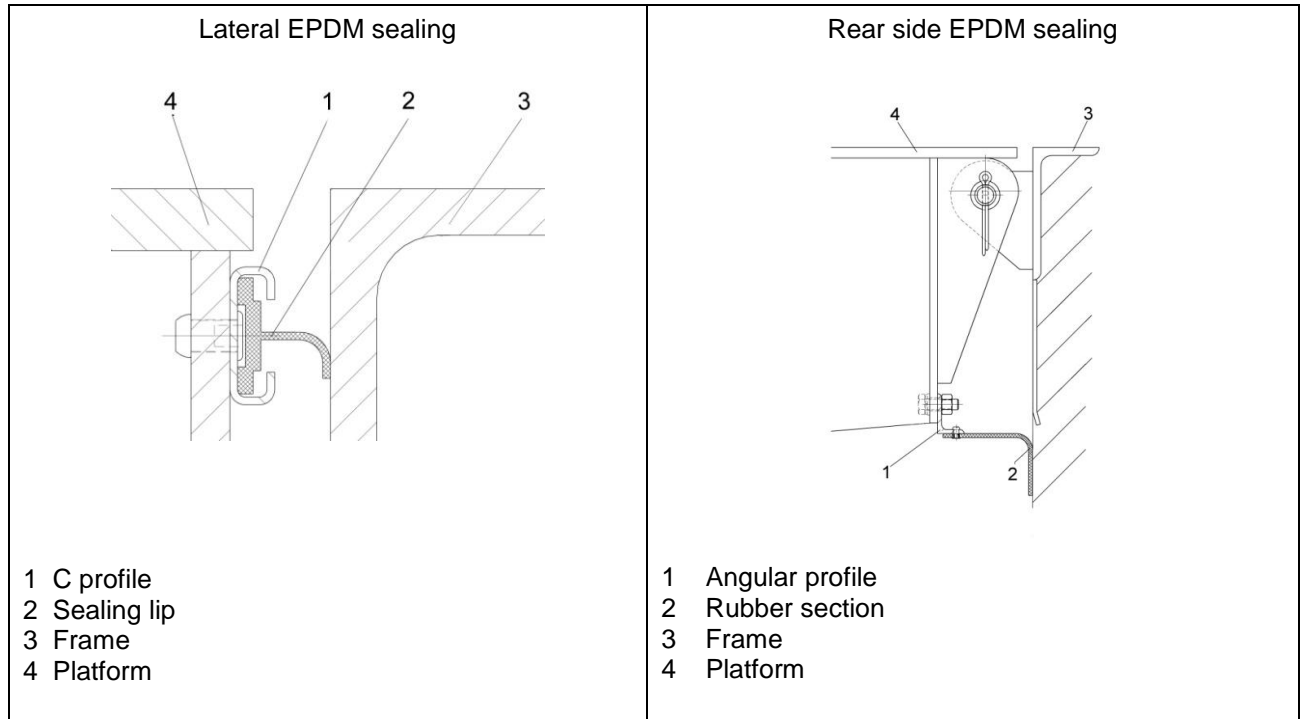

Anti-slip / anti-noise coating

As an option, it is possible to provide the platform and the telescopic lip with a special anti-slip / anti-noise layer. This coating consists of high-elasticity solvent-free polyurethane with a material thickness of 3-4 mm filled with sharp-edge broken basalt (grain size 1-1.6 mm).

This type of coating guarantees a high degree of anti-slip and anti-noise protection and is applied to profiled material. That's why the requirements of DIN EN 1398 regarding slip prevention are met even if this coating is damaged.

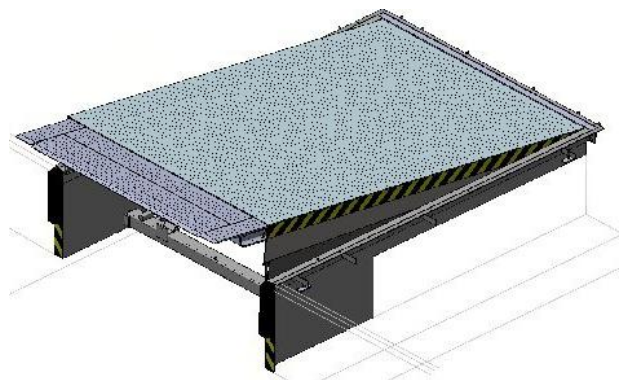

Front curtain

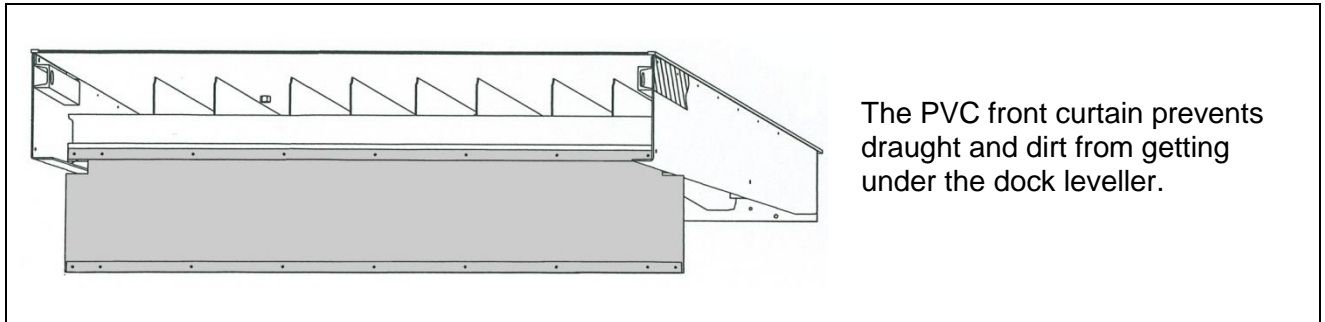

Platform insulation

In these days, energy saving is an important topic. Therefore, it is essential to optimally insulate the docking station. If the dock leveller is located outside the door opening, the platform insulation panel prevents cold or warm air from entering the warehouse inner area. The leveller platform is insulated by means of 40 mm or 60 mm insulation panels.

ISO-KIT

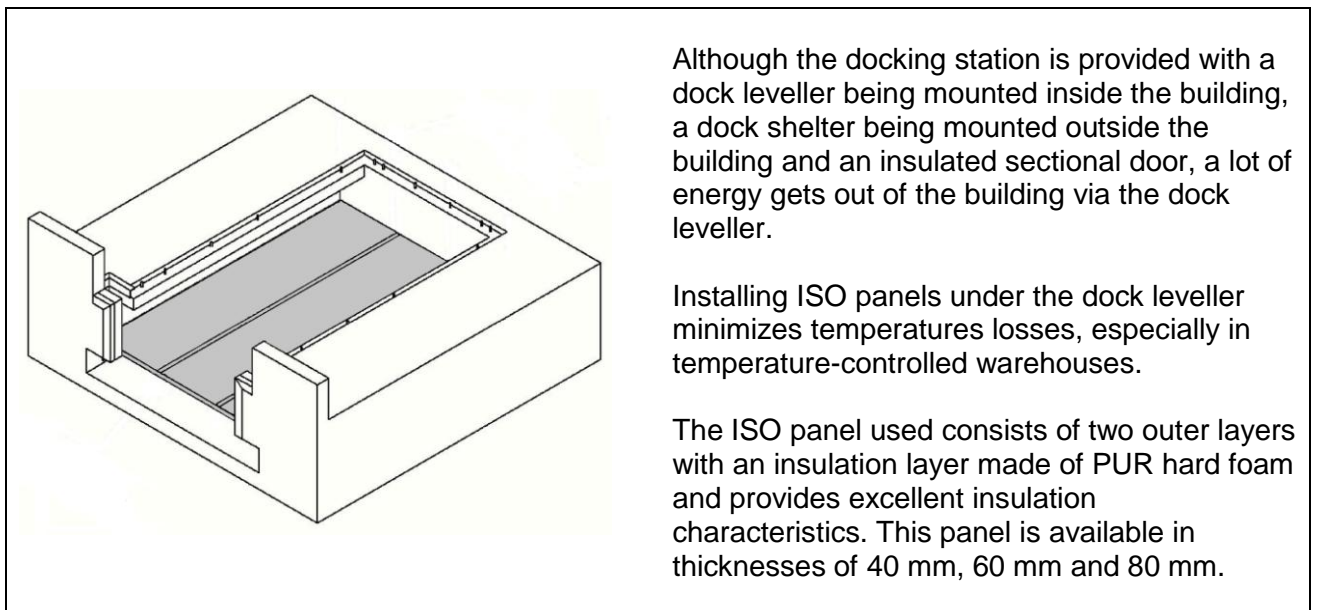

Surface treatment

Painting

Before final assembly, the individual components of the dock leveller are sandblasted and provided with a two-component paint. Standard RAL colours are RAL 5010 and RAL 7016 in a layer thickness of 80 µm. Further RAL colours and layer thicknesses of up to 160 µm are available as an option.

To increase corrosion protection, the dock leveller can also be delivered with hot-dip galvanized steel parts.

Hydraulic unit

The dock leveller is operated by means of a tried and tested under-oil hydraulic unit (1,5 kW). The closed system stands out for its high reliability even under very difficult operating conditions. We offer special hydraulic oils for use with low-temperature applications.

The dock leveller is lifted by means of two cylinders (Ø 45 mm) to ensure safe positioning even if the lorry leaves the dock during loading or unloading. In this case the down movement of the leveller has to be stopped; this is guaranteed by means of special emergency valves in the lift cylinders.

The telescopic lip is advanced by means of a cylinder with a piston rod of 22 mm in diameter (for a telescopic lip of 500 mm) and of 25 mm in diameter (for a telescopic lip of 1000 mm).

Frames / pits

T frame (to be embedded in concrete)

The leveller is directly cast into concrete including its frame.
 Advantage: fast and clean installation in one step.

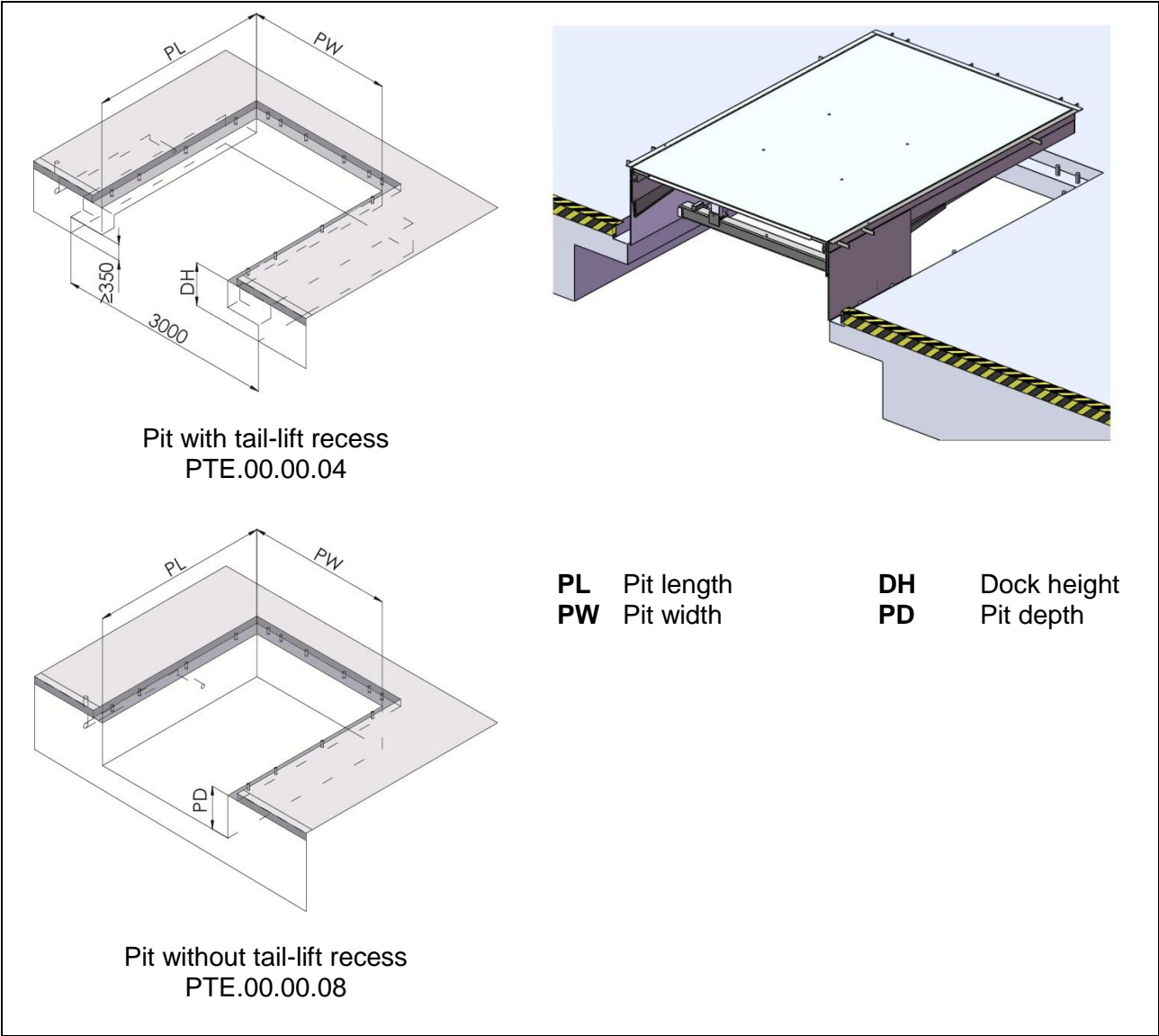

W frame (in combination with a pre-frame)

The frame can be mounted to the floor slab already before installation of the dock leveller itself. The leveller is then welded to the pre-installed frame. Pit preparations are identical for T and W-type frames so that maximum flexibility is guaranteed.

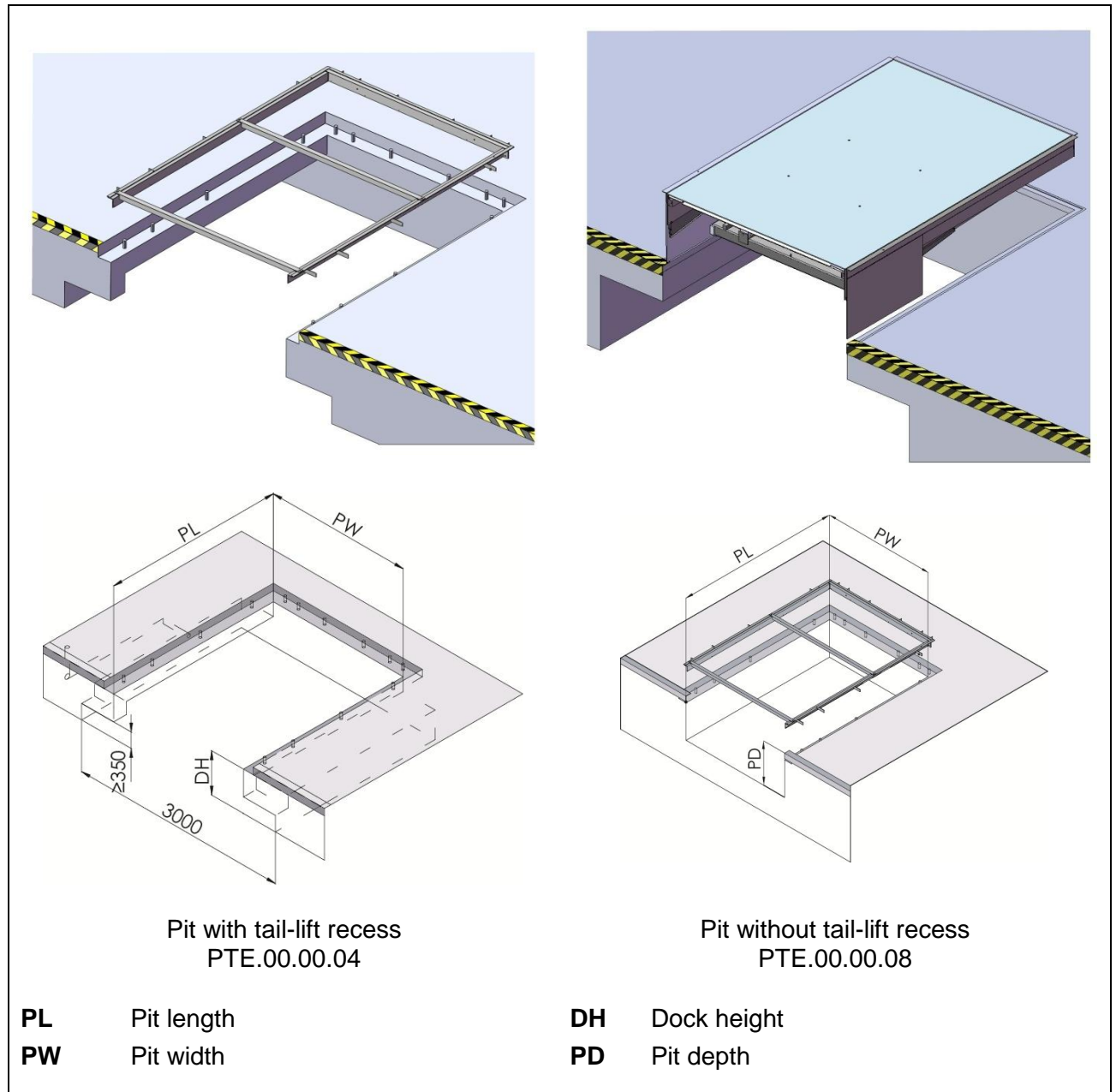

F frame (flat steel frame for leveller replacement)

This type of frame is used for easy and fast replacement of existing dock levellers. With the F-type frame the existing leveller is cut out of the pit and replaced by a new one. The existing frame is used again if it is not damaged and if its load capacity is sufficient. Thus, concrete work is not required.

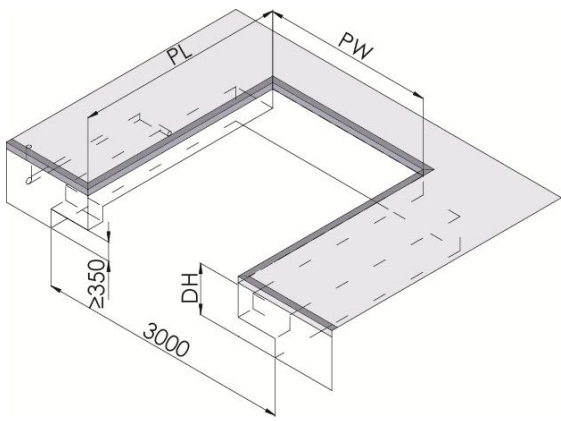

Pit with tail-lift recess
PTE.00.00.22

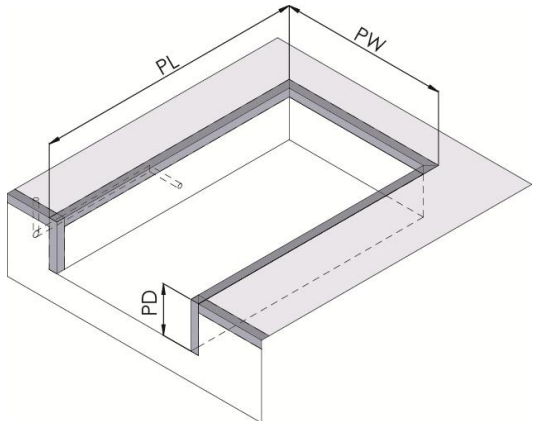
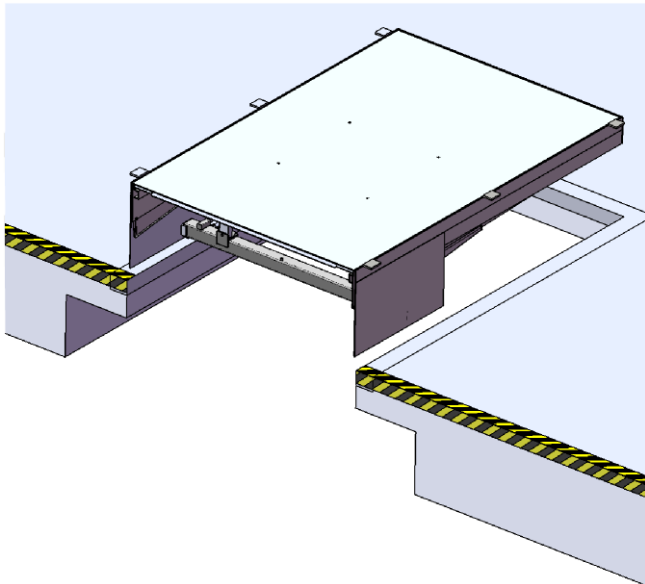

Pit without tail-lift recess
PTE.00.00.19

- PL** Pit length
- PW** Pit width
- DH** Dock height
- PD** Pit depth

P frame (mounted in the pit)

Fast and cost-effective installation of the leveller; only for pits without tail-lift recess

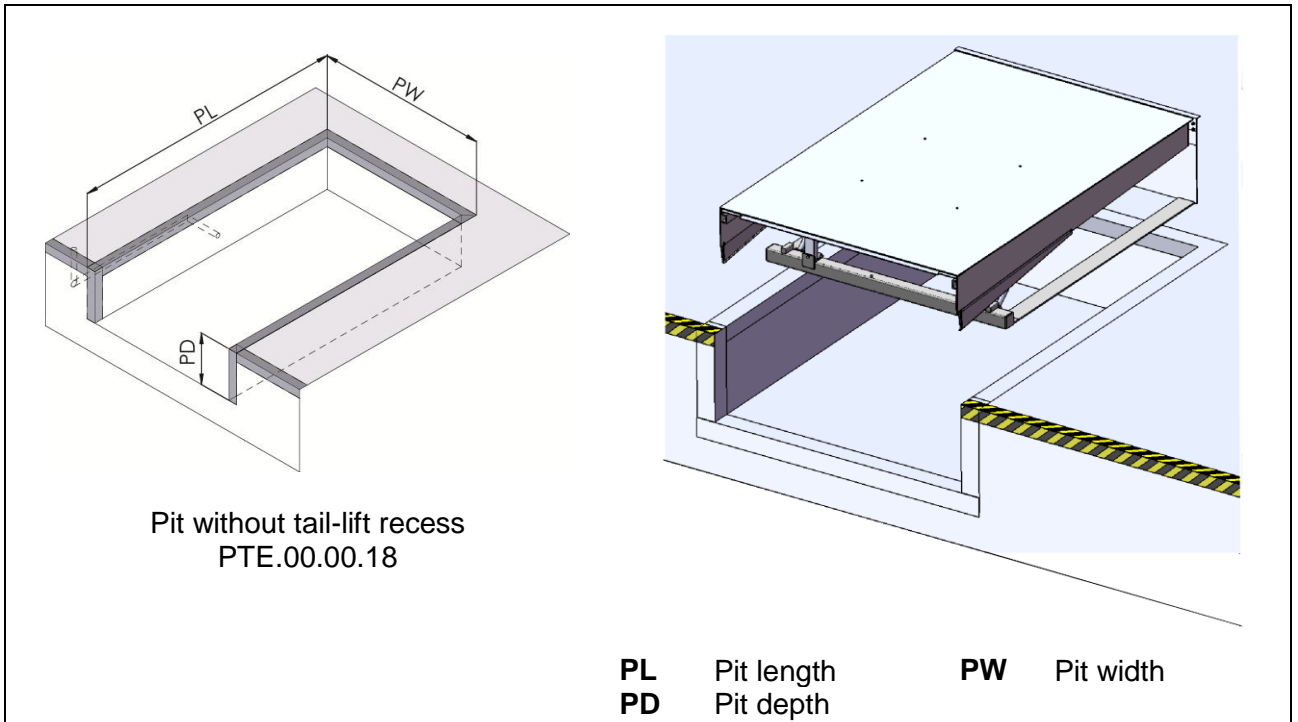

B (box)

No need to prepare a standard installation pit. Preparation of the building floor slab is much easier as boarding work is not necessary.

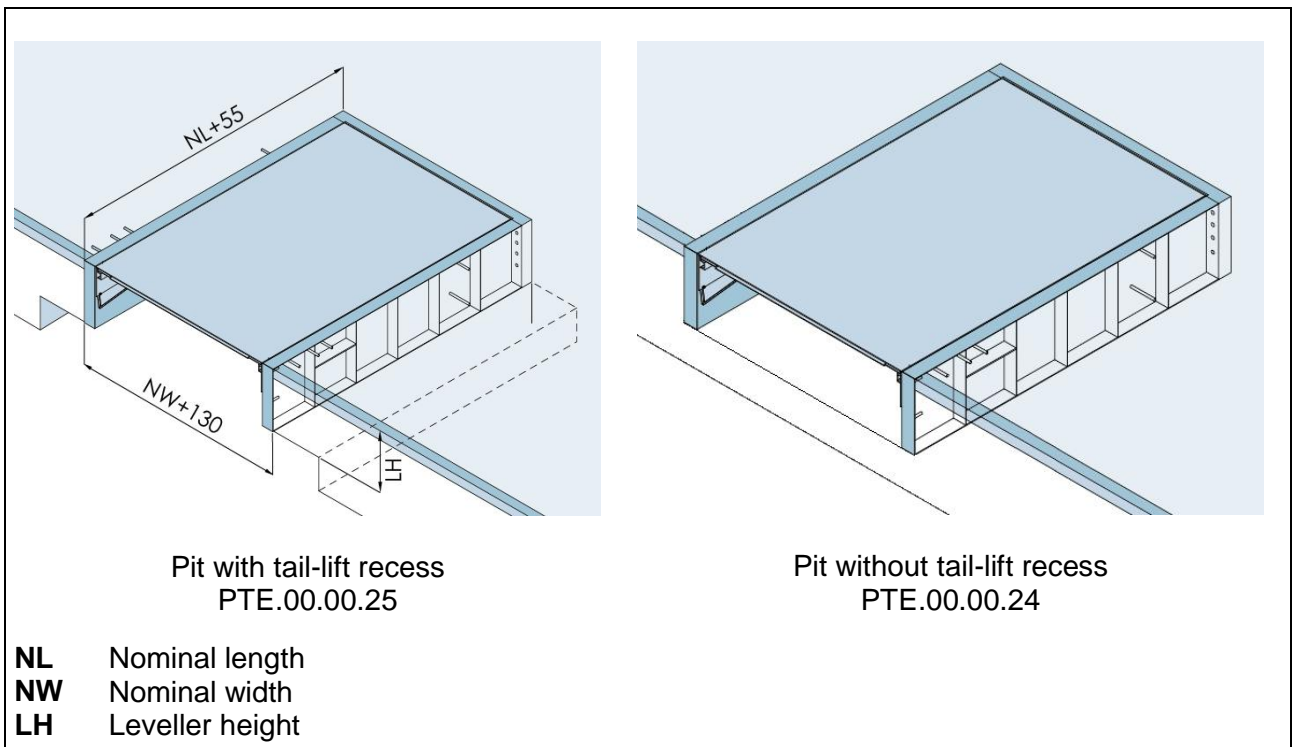

Stepped version

This type of installation is used when the lorry bed height is lower than the height of the ramp. In this case, the pit is provided with spaces on the right and on the left side of the leveller so that opening the vehicle doors for a docked-in lorry is possible without any problems.

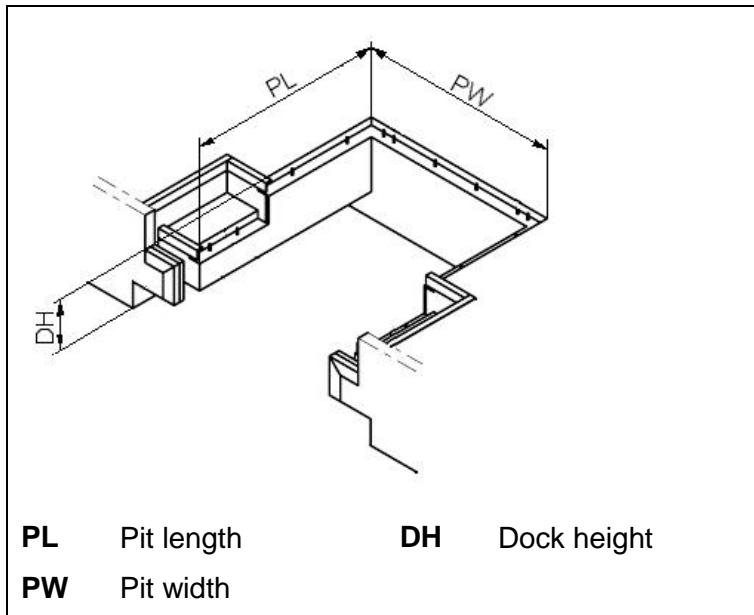

Control units

Standard DOCKController (PBES 2 MV 16)



- Main switch
- "Lift" button to lift the platform
- "Extend" button to position the lip on the lorry
- "Auto" button (to return the leveller to its resting position by shortly pushing this button)
- Connection possibility: leveller/door interlock / door/leveller interlock

Option PROMControl (PBES 2 MV 10 01)
easy programming, display

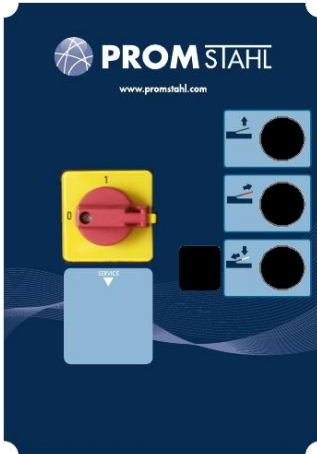

- Main switch
- "Lift" button to lift the platform
- "Extend" button to position the lip on the lorry
- "Auto" button (to return the leveller to its resting position by shortly pushing this button)
- Possibility of connecting a wheel chock, a vehicle detection system, traffic lights, a dock shelter and a door locking system

Option PROMControl (PBES 2 MV 15)
easy programming, operating status and error code display

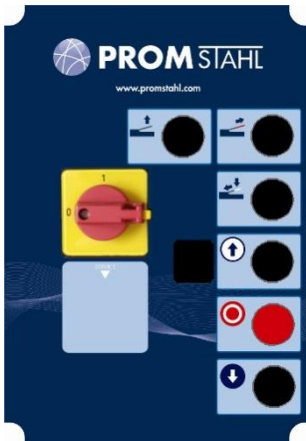

- Main switch
- "Lift" button to lift the platform
- "Extend" button to position the lip on the lorry
- "Auto" button (to return the leveller to its resting position by shortly pushing this button)
- Possibility of connecting a wheel chock, a vehicle detection system, traffic lights, dock lights, a pneumatic dock shelter and a door locking system
- Including door operation button

Option PROMControl (PBES 2 MV 17)
easy programming, operating status and error code display

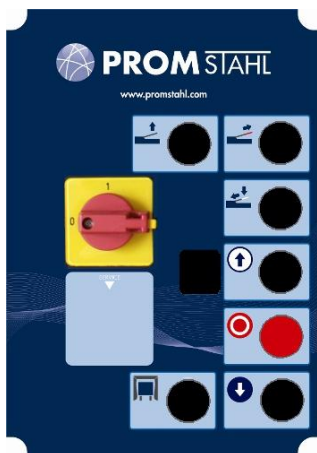

- Main switch
- "Lift" button to lift the platform
- "Extend" button to position the lip on the lorry
- "Auto" button (to return the leveller to its resting position by shortly pushing this button)
- Possibility of connecting a wheel chock, a vehicle detection system, traffic lights, dock lights, a pneumatic dock shelter and a door locking system
- Including door operation button and button for inflatable dock shelter

Option control unit (PBES 2 MV 01)
only for special sequences



- Main switch
- "Lift" button to lift the platform
- "Extend" button to position the lip on the lorry
- "Auto" button (to return the leveller to its resting position by shortly pushing this button)
- Possibility of connecting a wheel chock, traffic lights, dock lights and a door locking system

Accessories

Buffers

Fixed buffers as well as movable buffers are designed to absorb impact during the docking process protecting both the vehicle and the docking system. All rubber elements of our PROMStahl buffer series are made of high-quality rubber ensuring a long service life.

Fixed-position buffers

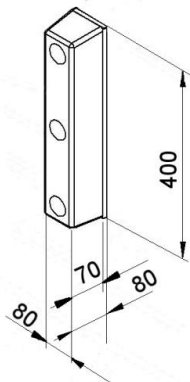

PGF 70
Rubber element (thickness 70 mm) with plate (hot-dip galvanized)

Standard high-quality rubber buffer with a high resistance to wear and tear for lower loading frequencies

PGF 90
 Rubber element (thickness 90 mm) with plate
 (hot-dip galvanized)

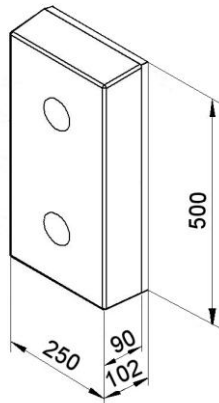

PGF 140
 Rubber element (thickness 140 mm) with plate
 (hot-dip galvanized)

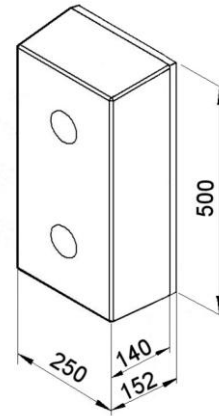

PGF 90 and PGF 140 are designed for extremely high impact forces

Height-adjustable buffers

PGV 90
 Buffer with vertical guide
 (rubber element: thickness 90 mm)

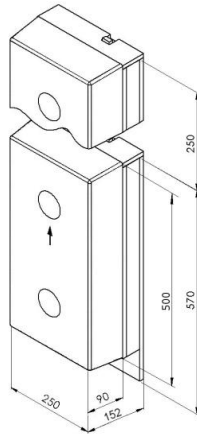

PGV 140
 Buffer with vertical rail guide
 (Rubber element: thickness 140 mm)

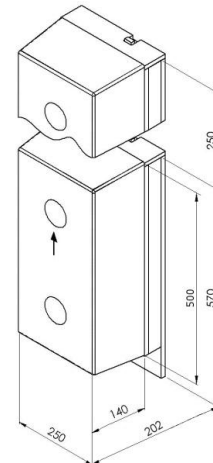

These buffers are used for loading and unloading of vehicles whose lorry beds are higher than dock level. Height-adjustable buffers can be lifted by up to 250 mm above dock edge. During loading and unloading the buffer adjusts to the lorry's vertical movements. It moves up to 50 mm upwards and 250 mm downwards. Thus, the buffer's wear is reduced to minimum and its durability is extended. After docking the buffer can be fixed at dock level so that the lorry tailgates can be opened.

Floating buffers

PGB 90
Buffer with vertical guide
(Rubber element: thickness 90 mm)

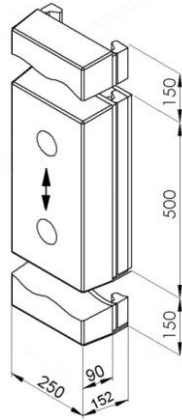

PGB 140
Buffer with vertical rail guide
(Rubber element: thickness 140 mm)

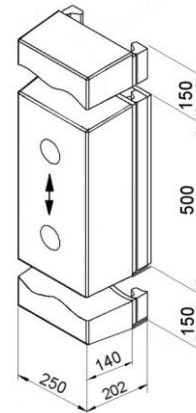

These buffers have the highest possible durability. They follow the lorry's vertical movements by 150 mm upwards and 150 mm downwards so that the buffers' wear is almost reduced to zero.

Buffers with protective housing

PGFS 90
Buffer with protective housing
(rubber element: thickness 90 mm)

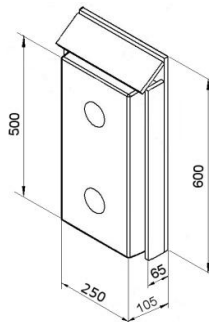

PGFS 140
Buffer with protective housing
(rubber element: thickness 140 mm)

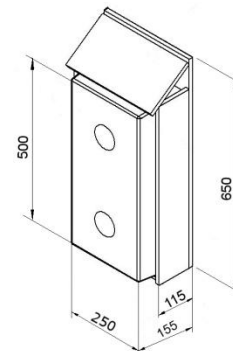

For higher impact loads buffers with protective housing are recommended. The sloped protective plate prevents the buffers from being heavily damaged. Thanks to the lateral flat steel guides the fixing bolts of rubber buffers are optimally protected against shearing.

Spring-steel buffer

PGS 600
Spring-steel buffer with plate (hot-dip galvanized)
Spring-steel plate (t=15 mm) and rubber buffer (Ø 130 mm)

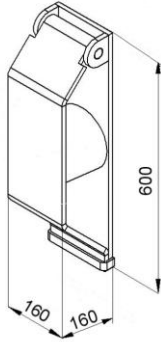

PGS 800
Spring-steel buffer with plate (hot-dip galvanized)
Spring-steel plate (t=15 mm) and rubber buffer (Ø 130mm)

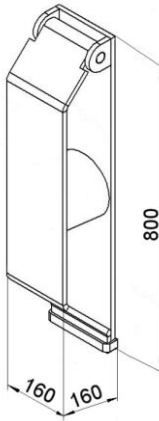

Spring-steel buffers provide optimum protection for heavy-duty loading and unloading. These buffers stand out for their excellent shock-absorbing characteristics, maximum resistance to wear and long service life. During loading/unloading only the buffer steel plate gets into contact with the vehicle. Thus, normal tear of the surface caused by the vehicle's height movements is excluded. Costly buffer replacement is avoided and operating costs are reduced. Spring-steel buffers are either welded to the frame or dowelled to the leveller. Optionally, it is possible to mount the buffer 200 mm above the dock edge by means of a support.

Wheel chock



The PZK wheel chock equipped with a position-dependent ultrasonic sensor and connected to the control unit via a robust cable guarantees safety during the whole loading and unloading process. As soon as one of the rear wheels of the lorry is stopped by means of the wheel chock, the leveller control function is “released” so that operation of the dock leveller can be started.

Traffic lights



Inside and outside traffic lights represent a reasonable completion of the docking station. It is recommended to provide the loading station not only with a wheel chock but also with a traffic lights system.

PROMStahl PBEA traffic lights systems assure communication between the lorry driver and the warehouse staff. They show the driver when the docking station can be approached and left safely. The traffic lights are connected to the PROMStahl control unit and adjustments/programming can be adapted to your individual requirements.

Dock light



In general, the danger of accidents during loading/unloading is very high due to bad lighting of the docking area. PROMStahl dock lights provide the best solution for perfect lighting of the docking area and the vehicle lorry bed.

Wheel guides

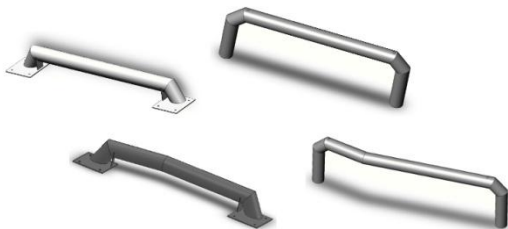

Wheel guides help the truck driver to reverse to the loading bay without any complicated maneuvering actions. They are installed on yard level, either by being cast directly into concrete (types PEK and PEKE) or by being bolted on the ground (types PEF and PEFE); they represent a good and reasonable investment into the safety at your loading bay.

Electrical preparations (by others)

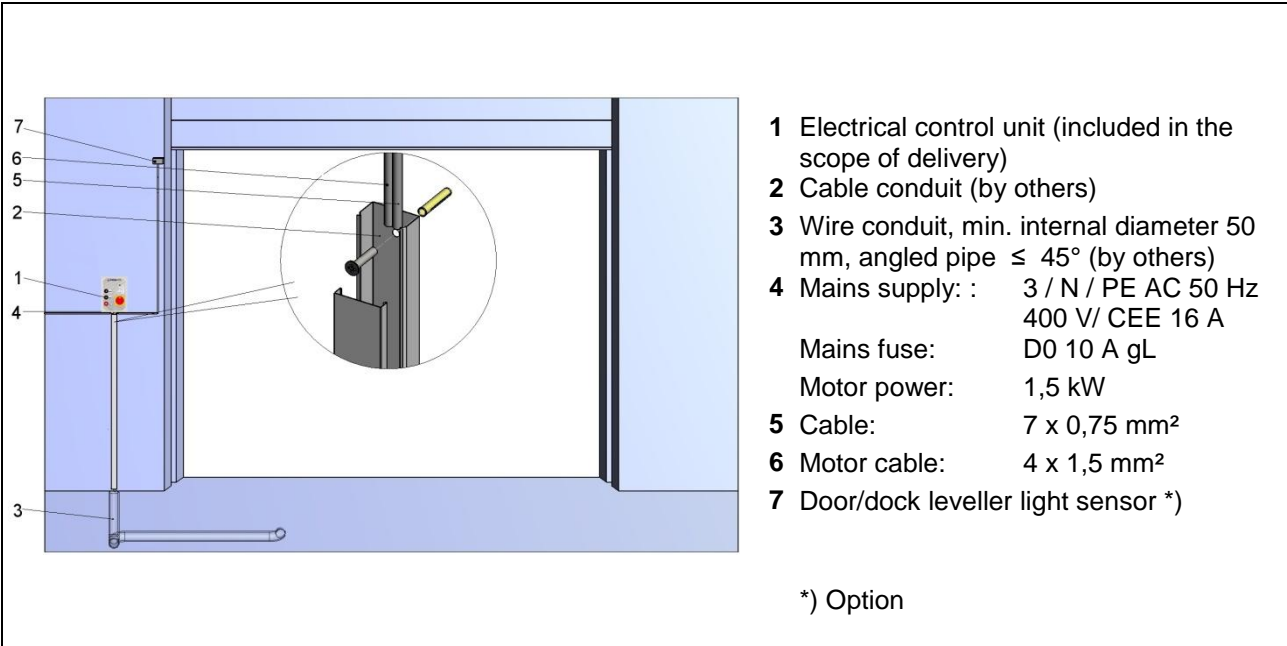

- 1 Electrical control unit (included in the scope of delivery)
- 2 Cable conduit (by others)
- 3 Wire conduit, min. internal diameter 50 mm, angled pipe $\leq 45^\circ$ (by others)
- 4 Mains supply: : 3 / N / PE AC 50 Hz
400 V/ CEE 16 A
Mains fuse: D0 10 A gL
Motor power: 1,5 kW
- 5 Cable: 7 x 0,75 mm²
- 6 Motor cable: 4 x 1,5 mm²
- 7 Door/dock leveller light sensor *)

*) Option