

Product datasheet

Hydraulic dock leveller with a segmented telescopic lip

Type: PTU

Load capacity: 60 kN/ 20 kN

Contact:



Ronnenberger Straße 20
D-30989 Gehrden

phone +49 (0) 5108 879 270
fax +49 (0) 5108 879 2710

info@promstahl.de
www.promstahl.de

Contents

- General information3
 - Overview.....3
 - Standard parameters4
 - Options5
- Telescopic lip5
 - Standard telescopic lip.....5
 - Telescopic lip options.....5
- Platform.....5
 - Toe guards5
 - EPDM sealing.....6
 - Anti-slip / anti-noise coating6
 - Platform insulation6
- Surface treatment.....7
 - Painting.....7
- Frames / pits7
 - T frame7
 - W frame7
 - F frame7
- Hydraulic unit8
- Control unit.....8
- Accessories.....9
 - Buffers9
 - Fixed-position buffers.....9
 - Wheel chock10
 - Traffic lights10
 - Dock light.....10
 - Wheel guides.....10
- Electrical preparations (by others)11

General information

PROMStahl's new product, the PTU, is a stationary electro-hydraulic dock leveller with a segmented telescopic lip. It represents the optimal solution for loading and unloading different types of vehicles like for example lorries and vans. This versatility leads to enormous cost savings.

The most important feature of this type of leveller is its segmented (3-part) telescopic lip. Depending on the type of vehicle docked (lorry or van) the operator chooses the related mode of operation on the control unit. For vans, only the 1200 mm segment in the middle of the telescopic lip is extended. In this case the leveller's load capacity is 20 kN. Thanks to the PTU's special design, the weight on the van is hydraulically reduced to about 100 kg.

For loading and unloading standard trucks, all three segments of the telescopic lip are automatically positioned on the lorry bed with their total width of 1950 mm. In that case, the load capacity of the dock leveller is increased to 60 kN. The PTU is operated electric-hydraulically at the push of a button; after exact positioning of the lip on the lorry bed, it follows the height variations of the vehicle being loaded or unloaded (automatic floating position).

The PROMStahl PTU dock leveller meets all requirements of the European standard EN 1398.

Overview

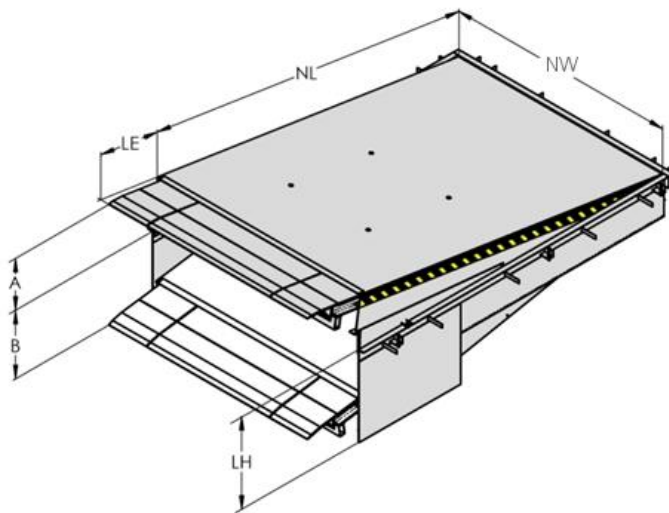

- NL Nominal length
- NW Nominal width
- LE Lip extension
- LH Leveller height
- A Level equalisation above dock
- B Level equalisation below dock

In accordance with the EN 1398 standard, the leveller must not be used beyond the permissible gradient range of $\pm 12.5\%$ (about $\pm 7^\circ$). The limits may only be exceeded if the operator ensures that the danger of slipping has been eliminated (e.g. due to dry and clean surfaces).

NL	NW	LH	LE = 500		LE = 1000	
			A	B	A	B
3000	2000	800	470	550	550	620
3500	2000	900	500	580	570	645
4000	2000	950	550	650	620	720
4500	2000	950	540	650	600	710

All dimensions in mm.

Load capacity for vans: 20 kN; load capacity for lorries: 60 kN
Other load capacities and sizes are available on request.

Lorry or van – just turn the switch!

The control panel of the PTU leveller is equipped with a switch by means of which its mode of operation can be selected. The operator just has to turn this switch either to the “Van” position or to the “Lorry” position and the relevant loading/unloading program is started. If the selector switch is set to “Van”, the side segments move backwards and reduce the lip width by 750 mm. Moreover, the load put on the van bed is automatically reduced. Turning the selector switch again, makes the PTU leveller return to the “Lorry” mode of operation.

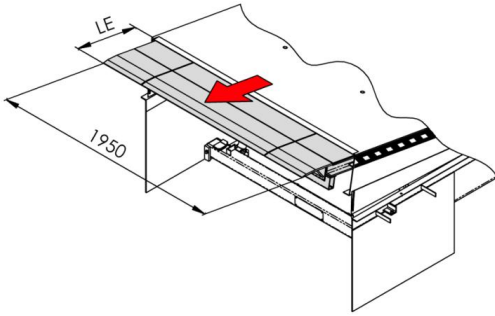

Lorry loading/unloading

The PTU dock leveller lip extends with its full width. The maximum load capacity of the leveller now is 60kN.

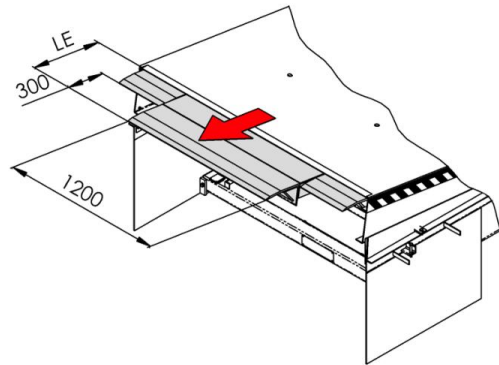

Van loading/unloading

Only the middle part of the telescopic lip is extended. The maximum load capacity of the leveller now is 20kN.

Standard parameters

Lip (steel)	Lip length: 500 mm Ground section: 40 mm Tear plate thickness: 13 mm/15 mm Width of the middle segment: 1200 mm Width of the side segments: 375 mm
Platform	Tear plate thickness: 10 mm/12 mm
Frame	T frame (leveller frame to be embedded in concrete) W frame (in combination with a pre-frame)
Surface	Painted, standard colours: RAL 5010, RAL 7016
Hydraulic unit	Hydraulic unit: - 2 lift cylinders with emergency stop valve - 2 lift cylinders for the telescopic lip
Control unit	Control unit with auto button

Options

Lip (steel)	Lip length: 1000 mm Ground section: 100 mm
Frame	F frame (for leveller replacement)
Surface	Painting in different RAL colours and various layer thicknesses Hot-dip galvanisation
Hydraulic unit	Organic oil Low-temperature oil
Control unit	Special control unit with additional options
Others	- EPDM sealing - Anti-slip coating - Platform insulation: ISO panel (thickness: 40 mm, 60 mm)

Telescopic lip

Standard telescopic lip

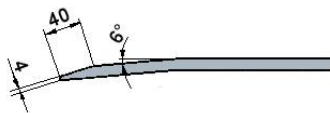

Ground section: 40 mm

The telescopic lip is made of a 13/15 mm tear-plate. For ergonomic reasons, the front part of the lip is bent by 6° and provided with a 40 mm ground section so that also very low vehicles can be loaded and unloaded without any problems.

Telescopic lip options

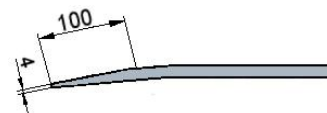

Ground section: 100 mm

The ground section of the lip can be extended to 100 mm so that transition from the telescopic lip to the lorry bed becomes even smoother.

Platform

Tear-plate thickness

The platform is made of high-quality tear plate material (S235JRG2) and supplied with a thickness of 10/12 mm.

It is strengthened by means of special reinforcements guaranteeing optimal stability as well as a sufficient transverse torsion strength of up to 10% of the platform's width.

Toe guards

The PTU dock leveller is always provided with lateral toe guards to prevent foot injuries when the leveller moves downwards.

EPDM sealing

The EPDM sealing is used to seal the gap between the dock leveller and the pit so that draught in the warehouse building is reduced, the staff's working conditions are improved and energy can be saved. The EPDM sealing is installed on the three sides of the leveller.

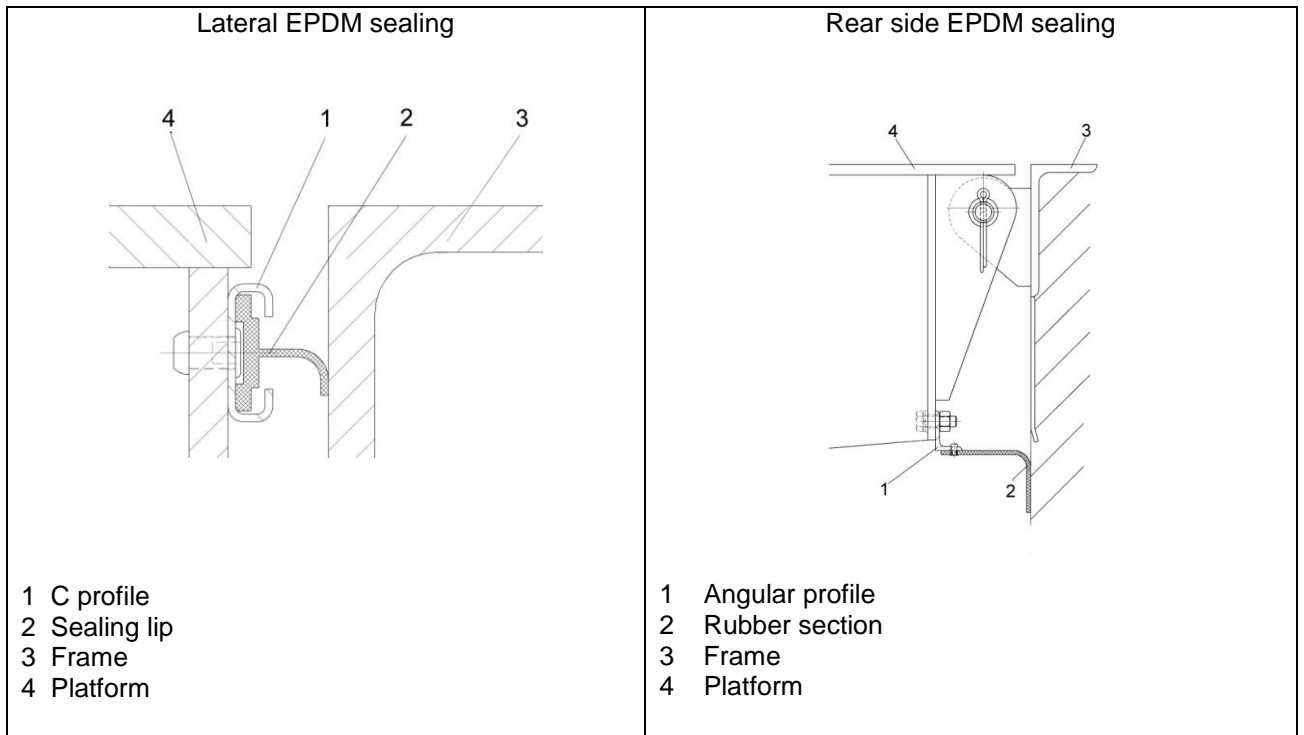

Anti-slip / anti-noise coating

As an option, it is possible to provide the platform and the telescopic lip with a special anti-slip / anti-noise layer. This coating consists of high-elasticity solvent-free polyurethane with a material thickness of 3-4 mm filled with sharp-edge broken basalt (grain size 1-1.6 mm).

This type of coating guarantees a high degree of anti-slip and anti-noise protection and is applied to profiled material. That's why the requirements of DIN EN 1398 regarding slip prevention are met even if this coating is damaged.

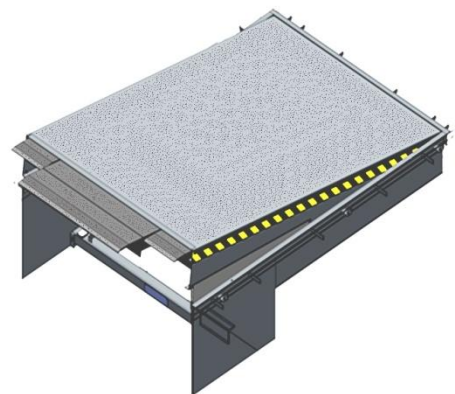

Platform insulation

In these days, energy saving is an important topic. Therefore, it is essential to optimally insulate the docking station. If the dock leveller is located outside the door opening, the platform insulation panel prevents cold or warm air from entering the warehouse inner area. The leveller platform is insulated by means of 40 mm or 60 mm insulation panels.

Surface treatment

Painting

Before final assembly, the individual components of the dock leveller are sandblasted and provided with a two-component paint. Standard RAL colours are RAL 5010 and RAL 7016 in a layer thickness of 80 µm. Further RAL colours and layer thicknesses of up to 160 µm are available as an option.

To increase corrosion protection, the dock leveller can also be delivered with hot-dip galvanized steel parts.

Frames / pits

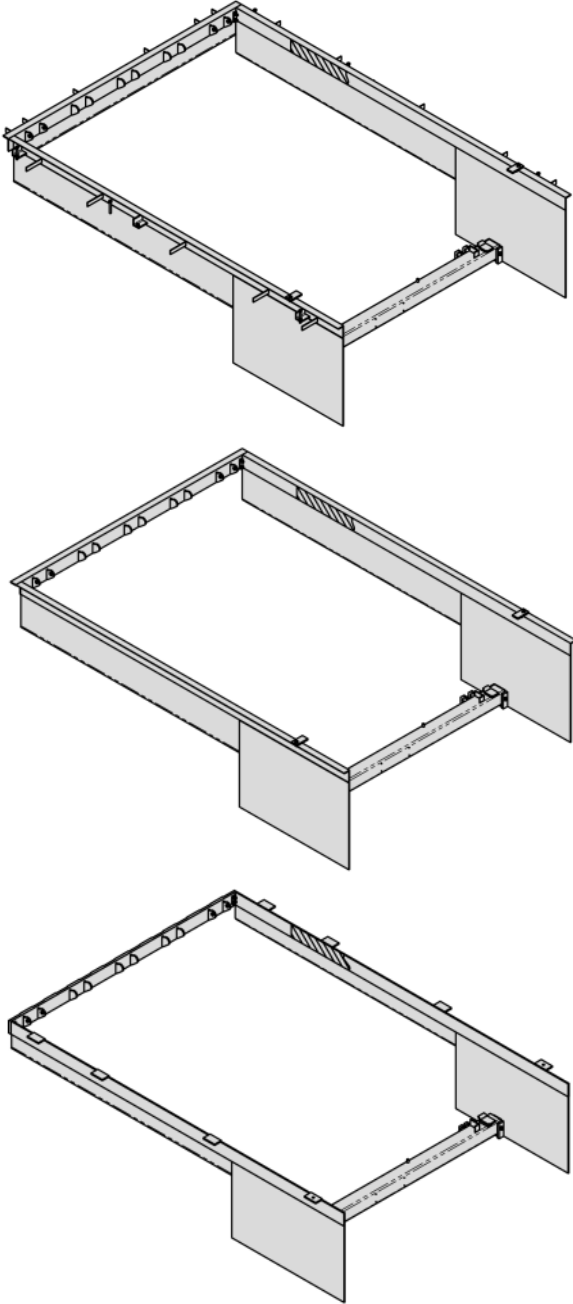

The diagrams show three types of dock leveller frames in a perspective view. Each diagram shows a rectangular frame with a central opening and a door mechanism on the right side. The T frame has a thick, solid frame. The W frame has a thinner frame with a distinct channel. The F frame has a frame with a different internal structure, designed for replacement.

T frame

The leveller is directly cast into concrete including its frame.
Advantage: fast and clean installation in one step.

W frame

The frame can be mounted to the floor slab already before installation of the dock leveller itself. The leveller is then welded to the pre-installed frame. Pit preparations are identical for T and W-type frames so that maximum flexibility is guaranteed.

F frame

This type of frame is used for easy and fast replacement of existing dock levellers. With the F-type frame the existing leveller is cut out of the pit and replaced by a new one. The existing frame is used again if it is not damaged and if its load capacity is sufficient. Thus, concrete work is not required.

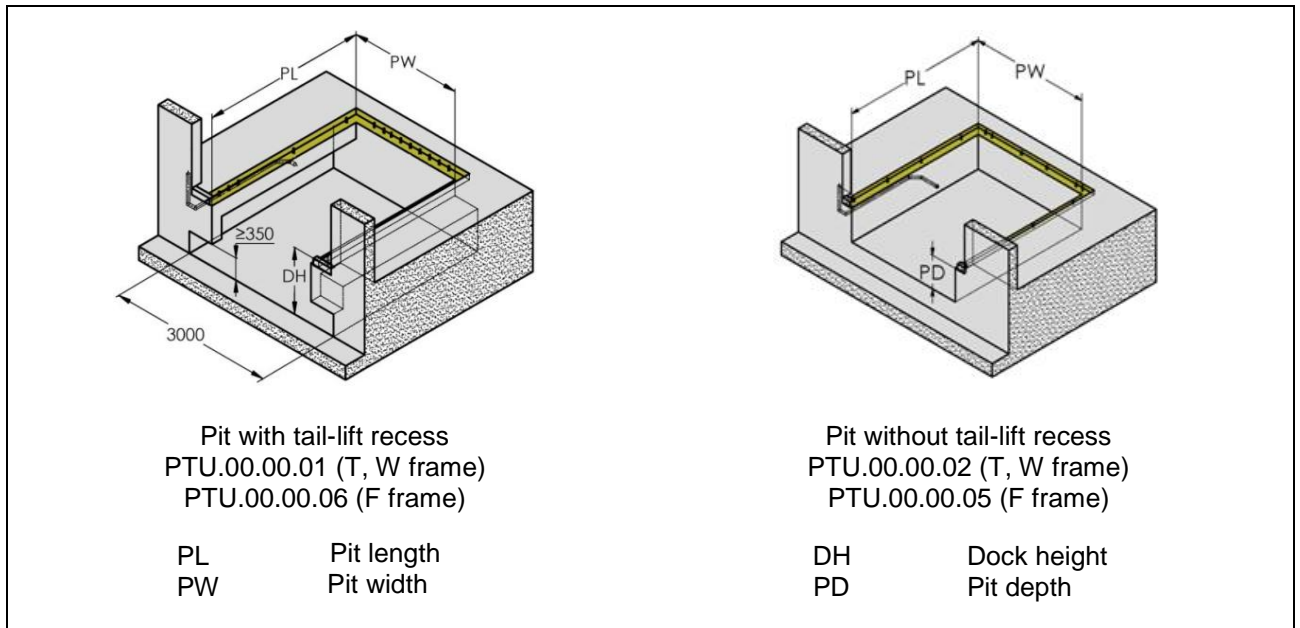

Hydraulic unit

The dock leveller is operated by means of a tried and tested under-oil hydraulic unit. The closed system stands out for its high reliability even under very difficult operating conditions. We offer special hydraulic oils for use with low-temperature applications.

The dock leveller is lifted by means of two cylinders (\varnothing 60mm) to ensure safe positioning even if the lorry leaves the dock during loading or unloading. In this case the down movement of the leveller has to be stopped; this is guaranteed by means of special emergency valves in the lift cylinders.

The telescopic lip is extended by means of two lip cylinders.

Control unit

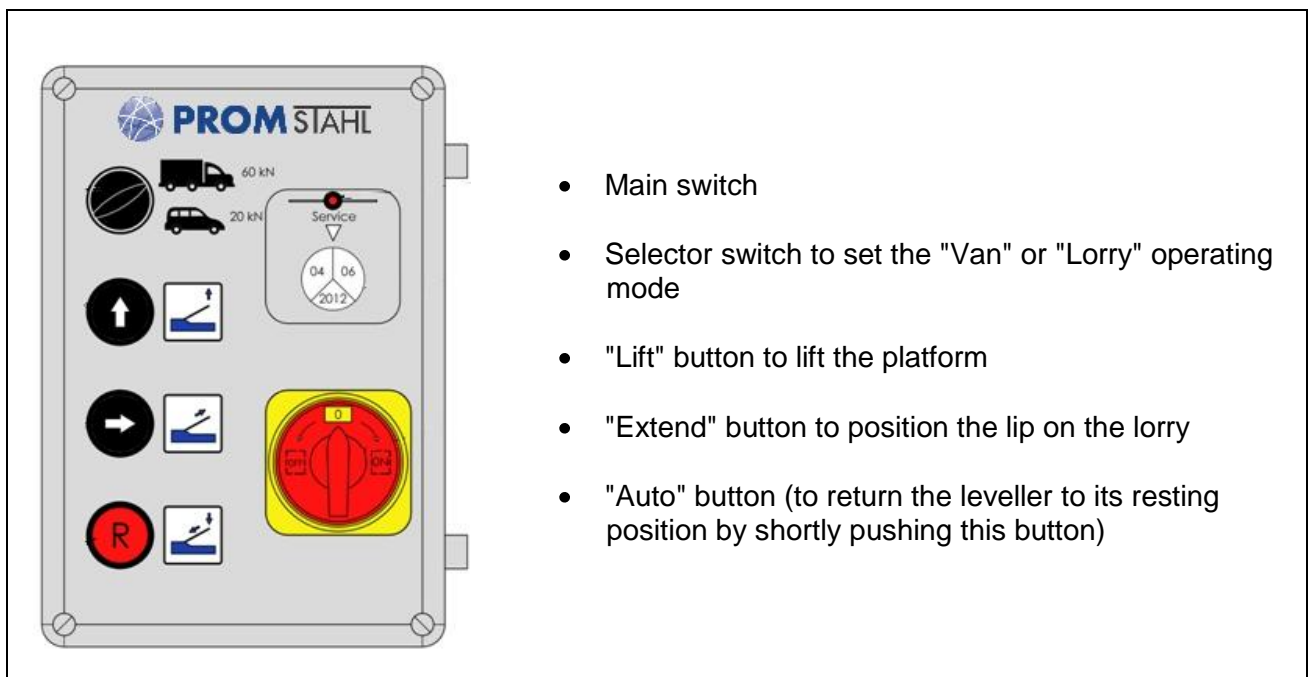

Accessories

Buffers

Fixed buffers as well as movable buffers are designed to absorb impact during the docking process protecting both the vehicle and the docking system. All rubber elements of our PROMStahl buffer series are made of high-quality rubber ensuring a long service life.

To provide maximum flexibility for the loading and unloading process, it is recommended to install two buffers on top of each other on both sides of the leveller.

Fixed-position buffers

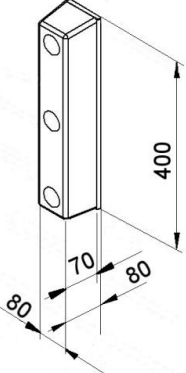
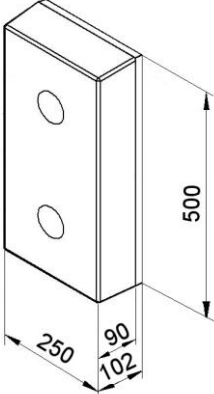
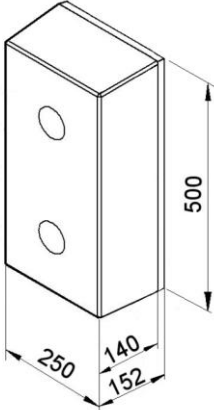
	<p>PGF 70 Rubber element (thickness 70 mm) with plate (hot-dip galvanized)</p> <p>Standard high-quality rubber buffer with a high resistance to wear and tear for lower loading frequencies.</p>
<p>PGF 90 Rubber element (thickness 90 mm) with plate (hot-dip galvanized)</p>	<p>PGF 140 Rubber element (thickness 140 mm) with plate (hot-dip galvanized)</p>
	
<p>These long service life buffers are designed for extremely high impact forces.</p>	

Wheel chock



The PZK wheel chock equipped with a position-dependent ultrasonic sensor and connected to the control unit via a robust cable guarantees safety during the whole loading and unloading process. As soon as one of the rear wheels of the lorry is stopped by means of the wheel chock, the leveller control function is “released” so that operation of the dock leveller can be started.

Traffic lights



Inside and outside traffic lights represent a reasonable completion of the docking station. It is recommended to provide the loading station not only with a wheel chock but also with a traffic lights system.

PROMStahl PBEA traffic lights systems assure communication between the lorry driver and the warehouse staff. They show the driver when the docking station can be approached and left safely. The traffic lights are connected to the PROMStahl control unit and adjustments/programming can be adapted to your individual requirements.

Dock light



In general, the danger of accidents during loading/unloading is very high due to bad lighting of the docking area. PROMStahl dock lights provide the best solution for perfect lighting of the docking area and the vehicle lorry bed.

Wheel guides

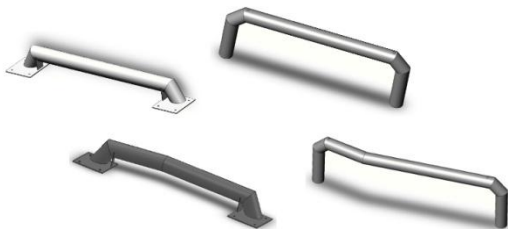

Wheel guides help the truck driver to reverse to the loading bay without any complicated maneuvering actions. They are installed on yard level, either by being cast directly into concrete (types PEK and PEKE) or by being bolted on the ground (types PEF and PEFE); they represent a good and reasonable investment into the safety at your loading bay.

Electrical preparations (by others)

