

Product datasheet

Loading ramp with swing lip leveller

Type: PAS

Load capacity: 60 kN

Contact:



Ronnenberger Straße 20
D-30989 Gehrden

phone +49 (0) 5108 879 270
fax +49 (0) 5108 879 2710

info@promstahl.de
www.promstahl.de

Contents

- General information3
 - Overview.....4
 - Lip length 4004
 - Lip length 5005
 - Standard parameters5
 - Options6
 - Design characteristics.....6
- Swing lip.....6
 - Standard swing lip6
 - Swing lip options.....6
 - Tapered lip.....7
 - Fold-down segments.....7
- Platform.....8
 - Tear-plate thickness.....8
 - Toe guards8
 - EPDM sealing8
 - Anti-slip / anti-noise coating9
- Surface treatment.....9
 - Painting.....9
- Hydraulic unit9
- Installation angles.....10
 - Installation angle 90° (standard)10
 - Further installation angle (option).....10
- Control units11
- Accessories.....12
 - Buffers12
 - Rubber elements without welding plate.....12
 - Fixed-position buffers.....12
 - Floating buffers13
 - Buffers with protective housing13
 - Spring-steel buffer14
 - Wheel chock15
 - Traffic lights15
 - Dock light.....15
 - Wheel guides15
- Electrical preparations (by others)16

General information

The PAS loading ramp is a new product of PROMStahl's wide product range. This top-quality product benefits from over 25 years of experience in designing and manufacturing docking systems.

The PAS ramp is a complete loading system which is mounted in front of a door opening or a building as a self-supporting unit. It consists of a hydraulic dock leveller with a swing lip and lateral treads which are reinforced on their bottom side. The PS leveller of the PAS system is operated at the touch of a button. As soon as the platform has reached its highest position the lip swings out automatically and comes to rest on the lorry bed. It optimally adapts to all lorry types both with respect to width as well as with respect to height. During loading and unloading the PROMStahl dock leveller follows the movements of the vehicle (automatic floating position).

The PROMStahl PAS system suggests itself as an extension to an existing building by means of a loading system as the necessary constructional preparation work is limited and operating costs are reduced. The PROMStahl PAS system can be installed at various angles (45°, 60°, 75°, 90°, 105°, 120°, 135°) at the front of the building so that it is possible to optimally utilize the available space and to guarantee smooth and efficient loading and unloading operations. The steel elements of the PAS system are available either hot-dip galvanized or painted.

The stepped version of the PROMStahl loading ramp enables docking of various types of vehicles and is used when the loading height of the vehicle is lower than the height of the loading station. The stepped version guarantees trouble-free opening of the vehicle doors after vehicle dock-in.

As an option the PROMStahl PAS system can be extended to form a PROMStahl loading house. The loading house is a cladding house that in combination with a loading ramp and a dock shelter forms an independent unit that can be installed in front of the building and includes all components of a loading station. Together with the loading ramp as the supporting structure the dock leveller, dock shelter and sectional door form a complex loading system.

The PROMStahl loading ramp meets the latest European standards (DIN EN 1398) and is GS certified.

Overview

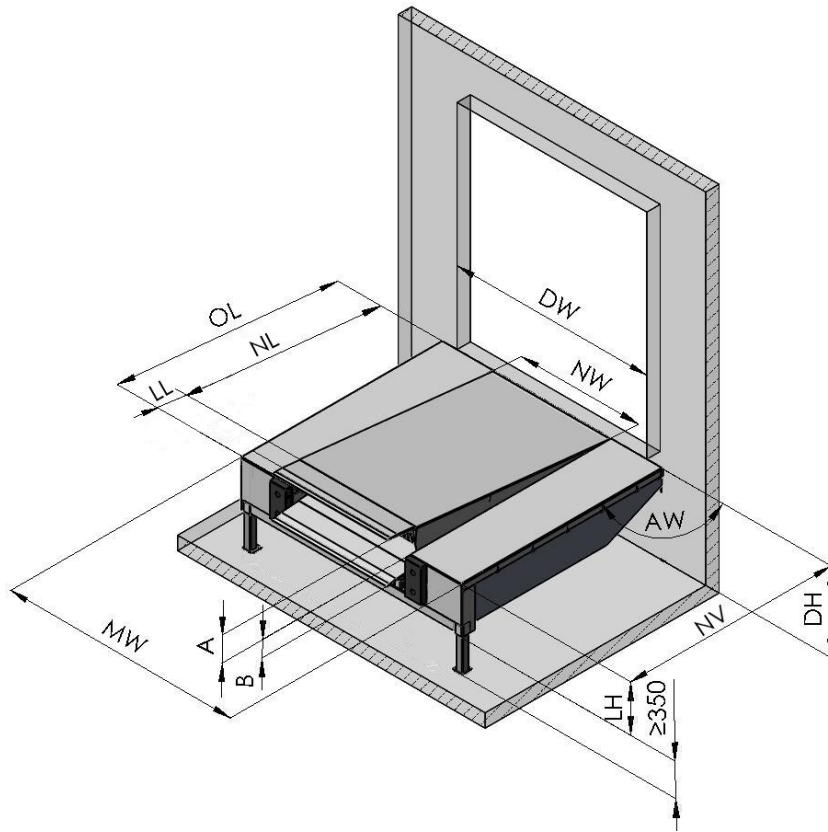

In accordance with the EN 1398 standard, the leveller must not be used beyond the permissible gradient range of $\pm 12.5\%$ (around $\pm 7^\circ$). The limits may only be exceeded if the operator ensures that the danger of slipping has been eliminated (e.g.: due to dry and clean surfaces).

NV	Loading ramp nominal length (NL + 20)
NL	Dock leveller nominal length
NW	Dock leveller nominal width
OL	Overall length (NL + LL)
LL	Lip length
LH	Leveller height
DH	Dock height
DW	Dock width
MW	Loading ramp module width
A	Level equalisation above dock
B	Level equalisation below dock
AW	Installation angle *

* All loading ramps are available with standard installation angles of 90° , $45^\circ/135^\circ$, $60^\circ/120^\circ$ and $75^\circ/105^\circ$. Further angles are available on request.

Lip length 400

LL	400			
NL	2000	2450	3000	3500
LH	700	700	700	800
A	290	345	430	520
B	340	320	330	350
OL	2400	2850	3400	3900
NW	All dimensions 1750, 2000, 2200, 2250			
MW	All dimensions 3300, 3500, 3600			

All dimensions in mm.

Load capacity for all dimensions: 60 kN (dynamic), 84 kN (static)
Other load capacities and dimensions on request.

Lip length 500

LL	500			
NL	2000	2450	3000	3500
LH	700	700	700	800
A	190	255	320	410
B	360	335	330	360
OL	2500	2950	3500	4000
NW	All dimensions 1750, 2000, 2200, 2250			
MW	All dimensions 3300, 3500, 3600			
All dimensions in mm.				

Load capacity for all dimensions: 60 kN (dynamic), 84 kN (static)
Other load capacities and dimensions on request

Standard parameters

- Dock leveller

Swing lip	Lip length: 400 mm Chamfered section: 40 mm Tear-plate thickness: 13 mm/15 mm
Platform	Tear-plate thickness: 6 mm/8 mm
Leveller height	LH ≥700 mm
Surface	Painted, standard colours: RAL 5010, RAL 7016
Hydraulic unit	Hydraulic unit: 0.75 kW 2 lift cylinders with emergency stop valve 1 lift cylinder for the swing lip
Control unit	Control unit (without auto button)

- Loading ramp

Module width	3300 mm
Installation angle	90°
Dock height	1100 mm to 1250 mm

Options

- Dock leveller

Swing lip	Lip length: 500 mm Chamfered section: 100 mm Swing lip with fold-down segments (125 mm on each side, only for lip length 400 mm) Swing lip with tapered edges (125 mm on both sides)
Platform	Tear-plate thickness: 8 mm/10 mm
Surface	Painting in different RAL colours and various layer thicknesses Hot-dip galvanisation
Hydraulic oil	Organic oil Low-temperature oil (- 30°C to + 60°C)
Control unit	Control unit with auto button Special control unit with additional options
Others	EPDM sealing Anti-slip / anti-noise coating

- Loading ramp

Module width	3500 mm, 3600 mm
Frame	Rear support frame (four-leg version)
Installation angle	Angular platform of 45°/135°, 60°/120°, 75°/105°
Dock height	950 mm to 1050 mm 1300 mm to 1500 mm

Design characteristics

The integrated PS dock leveller is provided with the CE and the GS (safety-tested) labels and meets all requirements of the EN 1398 standard. The standard load capacity of 60 kN (dynamic axle load) corresponds to the EN 1398 standard for a forklift wheel contact surface of 100x150 mm. Higher concentrated loads as well as higher load capacities are available on request.

Swing lip

Standard swing lip

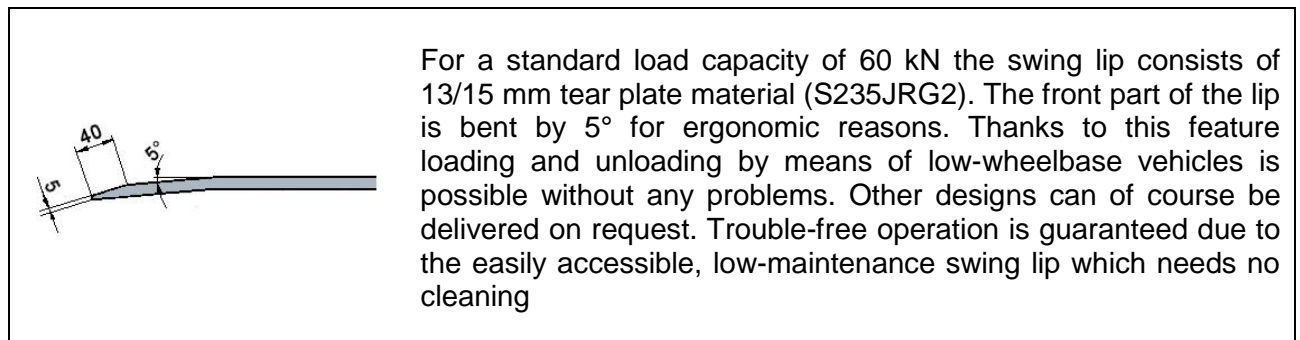

Swing lip options

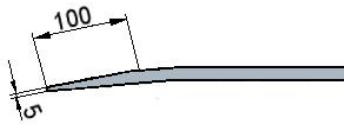

Chamfered section: 100 mm

The chamfered section of the lip can be extended to 100 mm so that transition from the swing lip to the lorry bed becomes even smoother.

Tapered lip

The most cost-effective way to reduce the contact area of the swing lip is to provide it with tapered edges on both sides. This option offers 125 mm bevels on both sides. Recommended for $NW > 2,200$ mm.

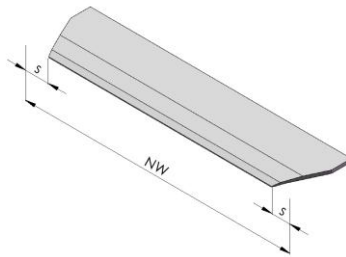
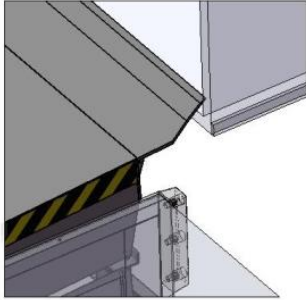

$s = 125$ mm

Fold-down segments

Our PS dock levellers are also available with fold-down segments. In this case the lip consists of a central element and two side elements (located on the left and right hand side). The side elements fold down independently of the central element. The lip width is reduced by 125 mm on each side so that vehicles with narrow beds can be also loaded and unloaded. When the lip returns to its rest position, the side elements are automatically locked with the central element so that the central element and the side elements are lifted together during the subsequent swing-out process.

Recommended for $NW > 2200$ mm. This option is only available for lip length: 400 mm.

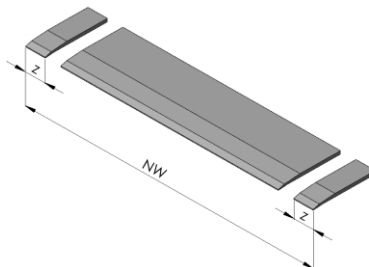
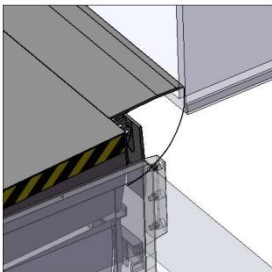

$z = 125$ mm

Platform

Tear-plate thickness

The platform is made of high-quality tear plate material (S235JRG2) and supplied with a thickness of 6/8 mm or optionally with 8/10 mm. It is strengthened by means of special reinforcements guaranteeing optimal stability as well as a sufficient transverse torsion strength of up to 10% of the platform's width.

Optimised connection between the platform and the lip guarantee safe operation and a long lifespan.

Toe guards

The dock leveller is always provided with lateral toe guards to prevent foot injuries when the leveller moves downwards.

EPDM sealing

The EPDM sealing is used to seal the gap between the dock leveller and the pit so that draught in the warehouse building is reduced, the staff's working conditions are improved and energy can be saved. The EPDM sealing is installed on the three sides of the leveller.

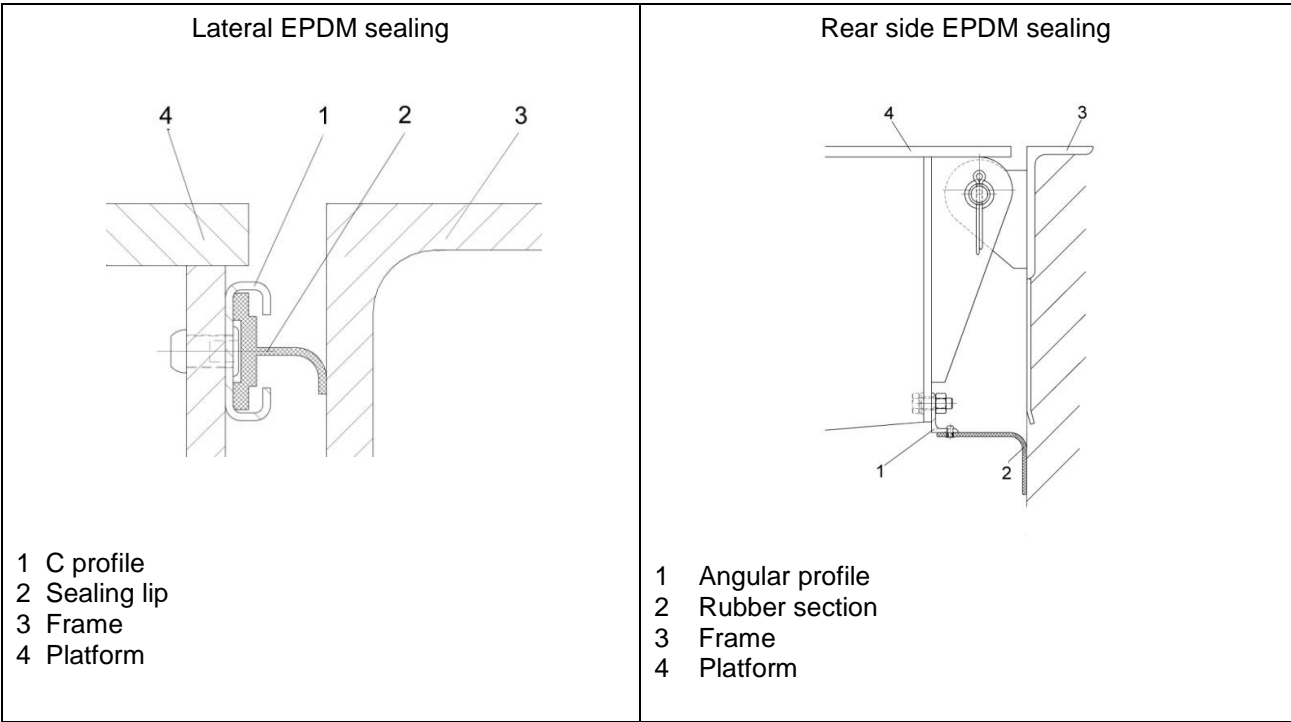

Anti-slip / anti-noise coating

As an option, it is possible to provide the platform and the swing lip with a special anti-slip / anti-noise layer. This coating consists of high-elasticity solvent-free polyurethane with a material thickness of 3-4 mm filled with sharp-edge broken basalt (grain size 1-1.6 mm).

This type of coating guarantees a high degree of anti-slip and anti-noise protection and is applied to profiled material. That's why the requirements of DIN EN 1398 regarding slip prevention are met even if this coating is damaged.

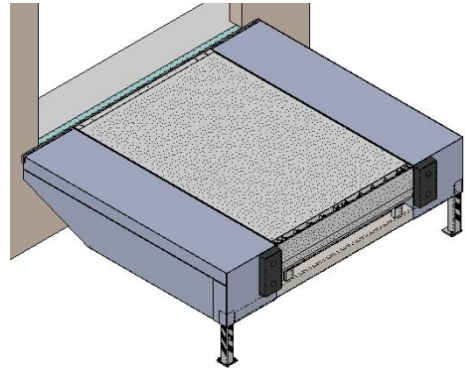

Surface treatment

Painting

Before final assembly, the individual components of the dock leveller are sandblasted and provided with a two-component paint. Standard RAL colours are RAL 5010 and RAL 7016 in a layer thickness of 80 µm. Further RAL colours and layer thicknesses of up to 160 µm are available as an option.

To increase corrosion protection, the dock leveller can also be delivered with hot-dip galvanized steel parts.

Hydraulic unit

The dock leveller is operated by means of a tried and tested hydraulic unit immersed in oil (0.75 kW). The closed system stands out for its high reliability even under very difficult operating conditions. We offer special hydraulic oils for use with low-temperature applications.

The dock leveller is lifted by means of two cylinders (Ø 35mm) to ensure safe positioning even if the lorry leaves the dock during loading or unloading. In this case the down movement of the leveller has to be stopped; this is guaranteed by means of special emergency valves in the lift cylinders.

The lip is swung out by means of a lip cylinder (Ø35 mm).

Installation angles

PROMStahl loading ramps are available with different installation angles which guarantee smooth and optimal loading and unloading processes even for small and complicated yard situations. In its standard version, the PROMStahl external loading ramp is delivered with an angle of 90°. Other installation angles are optionally available; for such a special installation angle, an angular platform is required to connect the building to the loading ramp.

Installation angle 90° (standard)

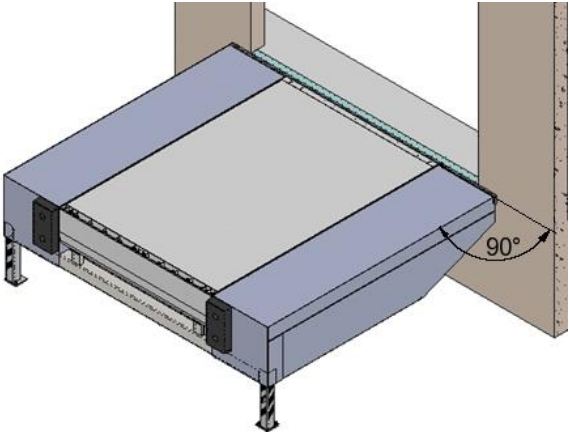

Further installation angle (option)

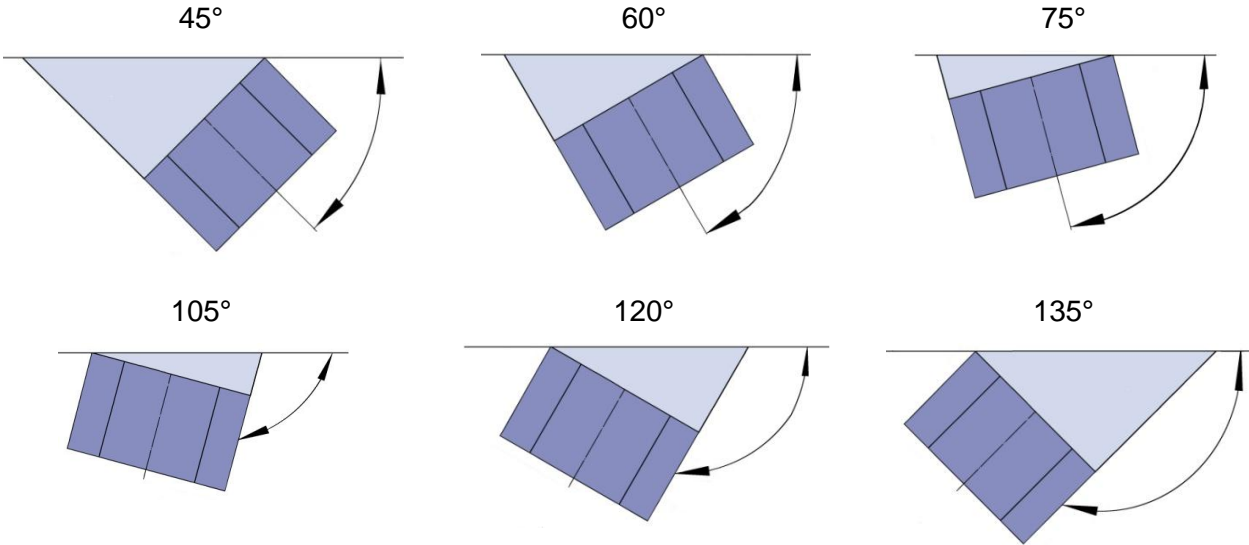

Control units

Standard DOCKController PS, without auto button (PBES 1MV 15)



- Main switch
- „Lift“ button to lift the platform and to swing out the lip and position it on the lorry bed
- „Lift“ button to return the leveller to its rest position
- Possibility of connecting an industrial door
- Connection possibility: door/leveller interlocking via door control unit or via a sensor (NO or NC contact)

Option PROMControl (PBES 1 MV 07)

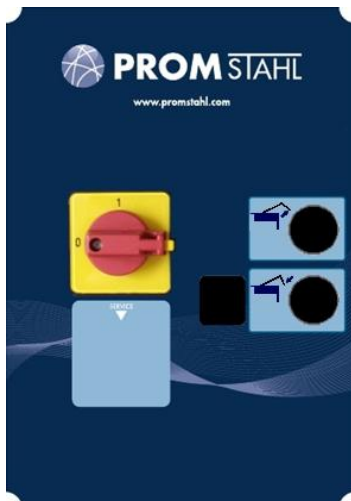

- Main switch
- „Lift“ button to lift the platform and to swing out the lip and position it on the lorry bed
- „Lift“ button return the leveller its rest position
- "Auto" button (to return the leveller to its resting position by shortly pushing this button)
- Possibility of connecting a wheel chock, a vehicle detection system, traffic lights, dock lights, a pneumatic dock shelter and a door locking system.

Option PROMControl (PBES 1 MV 06)



- Main switch
- „Lift“ button to lift the platform and to swing out the lip and position it on the lorry bed
- „Lift“ button return the leveller its rest position
- "Auto" button (to return the leveller to its resting position by shortly pushing this button)
- Possibility of connecting a wheel chock, traffic lights and a dock light
- Possibility of connecting a wheel chock, a vehicle detection system, traffic lights, dock lights, a pneumatic dock shelter and a door locking system.
- Including door operation button

Accessories

Buffers

Fixed buffers as well as movable buffers are designed to absorb impact during the docking process protecting both the vehicle and the docking system. All rubber elements of our PROMStahl buffer series are made of high-quality rubber ensuring a long service life.

Rubber elements without welding plate

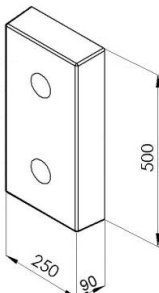
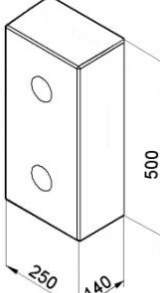
	<p>PBGP 90</p> <p>Dimension [mm]: 500x250x90</p>		<p>PBGP 140</p> <p>Dimension [mm]: 500x250x140</p>
---	---	--	---

The rubber buffers consist of high-quality new rubber material and stand out for their high resistance to wear and tear; they are available in two different versions.

Fixed-position buffers

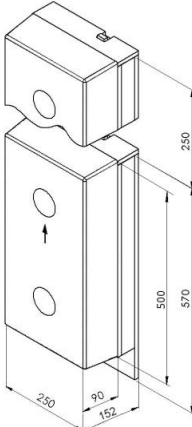
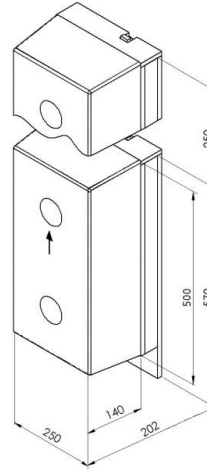
<p>PGV 90 Buffer with vertical guide (rubber element: thickness 90 mm)</p> 	<p>PGV 140 Buffer with vertical rail guide (Rubber element: thickness 140 mm)</p> 
---	--

These buffers are used for loading and unloading of vehicles whose lorry beds are higher than dock level. Height-adjustable buffers can be lifted by up to 250 mm above dock edge. During loading and unloading the buffer adjusts to the lorry's vertical movements. It moves up to 50 mm upwards and 250 mm downwards. Thus, the buffer's wear is reduced to minimum and its durability is extended. After docking the buffer can be fixed at dock level so that the lorry tailgates can be opened.

Floating buffers

PGB 90
 Buffer with vertical guide
 (Rubber element: thickness 90 mm)

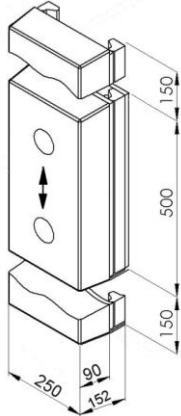

PGB 140
 Buffer with vertical rail guide
 (Rubber element: thickness 140 mm)

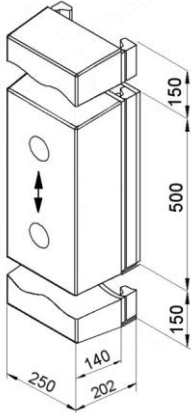

These buffers have the highest possible durability. They follow the lorry's vertical movements by 150 mm upwards and 150 mm downwards so that the buffers' wear is almost reduced to zero.

Buffers with protective housing

PGFS 90
 Buffer with protective housing
 (rubber element: thickness 90 mm)

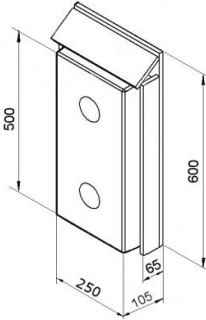

PGFS 140
 Buffer with protective housing
 (rubber element: thickness 140 mm)

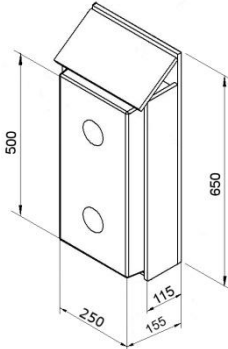

For higher impact loads buffers with protective housing are recommended. The sloped protective plate prevents the buffers from being heavily damaged. Thanks to the lateral flat steel guides the fixing bolts of rubber buffers are optimally protected against shearing.

Spring-steel buffer

PGS 600

Spring-steel buffer with plate (hot-dip galvanized)

Spring-steel plate (t=15 mm) and rubber buffer (Ø 130 mm)

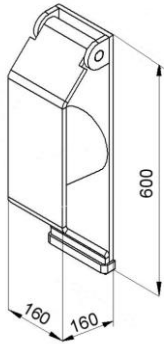

PGS 800

Spring-steel buffer with plate (hot-dip galvanized)

Spring-steel plate (t=15 mm) and rubber buffer (Ø 130mm)

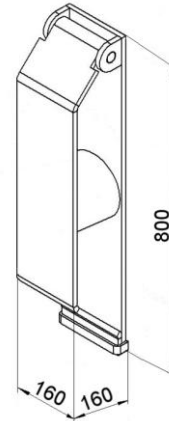

Spring-steel buffers provide optimum protection for heavy-duty loading and unloading. These buffers stand out for their excellent shock-absorbing characteristics, maximum resistance to wear and long service life.

During loading/unloading only the buffer steel plate gets into contact with the vehicle. Thus, normal tear of the surface caused by the vehicle's height movements is excluded. Costly buffer replacement is avoided and operating costs are reduced.

The spring-steel buffer is either welded to the frame or dowelled to the leveller.

Optionally, it is possible to mount the buffer 200 mm above the dock edge by means of a support.

Wheel chock



The PZK wheel chock equipped with a position-dependent ultrasonic sensor and connected to the control unit via a robust cable guarantees safety during the whole loading and unloading process. As soon as one of the rear wheels of the lorry is stopped by means of the wheel chock, the leveller control function is “released” so that operation of the dock leveller can be started.

Traffic lights



Inside and outside traffic lights represent a reasonable completion of the docking station. It is recommended to provide the loading station not only with a wheel chock but also with a traffic lights system.

PROMStahl PBEA traffic lights systems assure communication between the lorry driver and the warehouse staff. They show the driver when the docking station can be approached and left safely. The traffic lights are connected to the PROMStahl control unit and adjustments/programming can be adapted to your individual requirements.

Dock light



In general, the danger of accidents during loading/unloading is very high due to bad lighting of the docking area. PROMStahl dock lights provide the best solution for perfect lighting of the docking area and the vehicle lorry bed.

Wheel guides

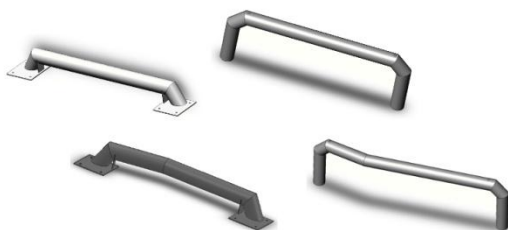

Wheel guides help the truck driver to reverse to the loading bay without any complicated maneuvering actions. They are installed on yard level, either by being cast directly into concrete (types PEK and PEKE) or by being bolted on the ground (types PEF and PEFE); they represent a good and reasonable investment into the safety at your loading bay.

Electrical preparations (by others)

